

CERAMIC CHIMNEY LINERS

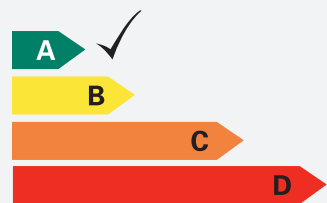

**ENABLING ENERGY
EFFICIENCY**

Ceramic Flue Liner

In order to meet the new European Standards for Chimney products, specific leakage and performance criteria have to be met, which are much more stringent than in the past.

Schiedel have invested in the latest production technology and are proud to introduce a new range of high performance rebated ceramic flue liners, which are fully CE tested and approved and are fully compatible with the increasingly efficient modern appliances, as well as meeting the more traditional soot fire requirements.

This new generation of rebated ceramic chimney liners is available as standard in the following diameter range:- 160mm, 180mm, 200mm.

Joint Detail

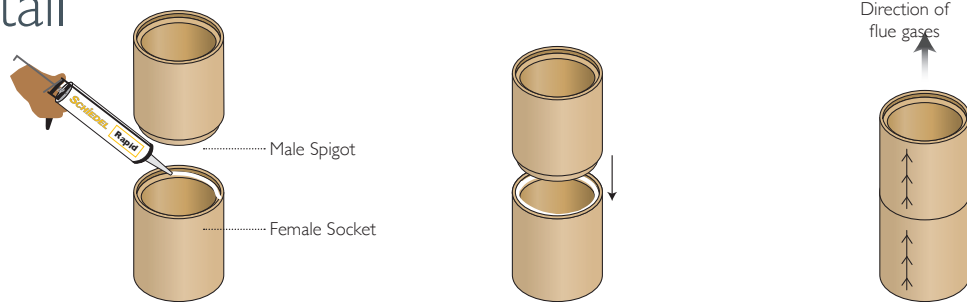

Liners are installed with the male spigot pointing downwards. Sealant should be applied to the inside of the female socket and any excess projecting into the flue should be wiped off as installation progresses.



Approvals



Schiedel Ceramic Liners are CE Certified to EN 1457-1 & 2 TÜV 0780 CPD 131086 with the following designations:

High Temperature Applications	Low Temperature Applications
EN 1457-1 A1 NI (T600 NI G)	EN 1457-2 B4 NI (T400 NI WC O) D4 NI (T200 NI WC O)*

* When used on T200 rated low temperature systems, the liner system should be straight and fully ventilated.

Usage of Ceramic Sealant & Light Expanded Clay Aggregate

RAPID HT CEMENT USAGE

Int Ø (mm)	No. Joints per tube
160	9
180	7
200	6

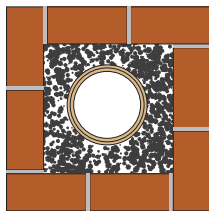

LIGHT EXPANDED CLAY AGGREGATE INSULATION REQUIREMENT FOR BACKFILL

Int Ø (mm)	Ext Ø (mm)	Chimney Void (mm)	Chimney Void (inches)	Bags per linear metre
160	190	235 × 235	9" × 9"	0.48
160	190	235 × 350	9" × 14"	1.02
160	190	350 × 350	14" × 14"	1.82
180	210	235 × 235	9" × 9"	1.08
180	210	235 × 350	9" × 14"	1.62
180	210	350 × 350	14" × 14"	2.42
200	230	350 × 350	14" × 14"	2.15
200	230	350 × 460	14" × 18"	2.49
200	230	460 × 460	18" × 18"	4.20

Offsets

Diameter (mm)	Bends 30°	Length 330mm	Total Height	Total Offset
160	2	0	596	155
160	2	1	880	320
180	2	0	600	161
180	2	1	888	326
200	2	0	596	160
200	2	1	881	325

Diameter (mm)	Bends 45°	Length 330mm	Total Height	Total Offset
160	2	0	545	222
160	2	1	779	455
180	2	0	545	226
180	2	1	779	460
200	2	0	545	226
200	2	1	779	460

Diameter (mm)	Bends 37.5°	Length 330mm	Total Height	Total Offset
160	2	0	580	197
160	2	1	842	398
180	2	0	569	193
180	2	1	830	394
200	2	0	568	190

SUPPORTING AN OFFSET

The bends and liners that make up an offset must be supported adequately

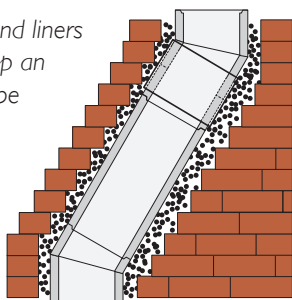

OFFSET WITH 2 BENDS & LINER

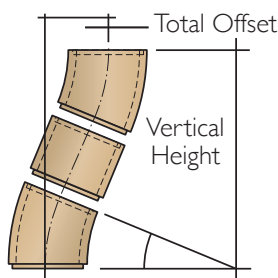

OFFSET WITH 2 BENDS

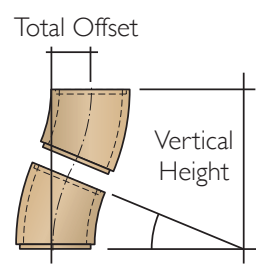

Typical Liner Installation Detail

Construction begins by providing a suitable foundation and constructional hearth in accordance with Building Regulations and site requirements.

STOVE IN RECESS OPTION

Our pre stressed lintels can be installed above the fireplace recess, for this method a support plate is required under the support block.

Alternatively a suitable cast-in-situ concrete slab lintel can be created above the fireplace recess. (See our standard drawings for hole size depending on diameter of chosen flue).

The support block is bedded onto the slab lintel using weak mix mortar. A stainless steel adaptor is used to connect from the support block to the stove flue pipe. This adaptor is pushed up onto the support block spigot (fibre rope should be used to create a seal). It is recommended to have a minimum of 600mm length of flue pipe before connecting to the chimney.

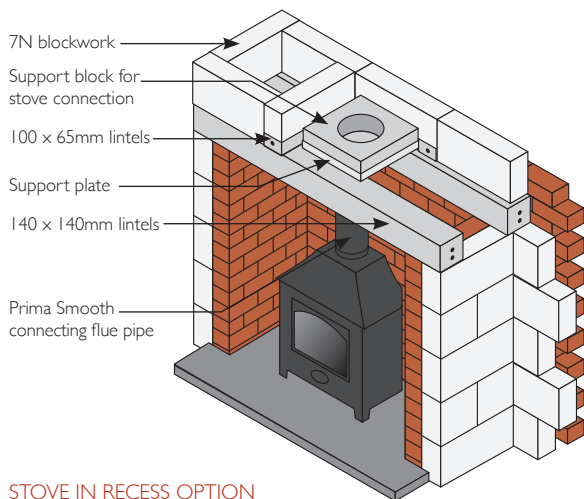
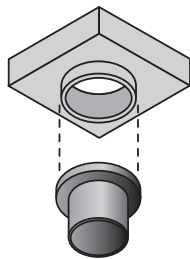

STOVE IN RECESS OPTION

FREE STANDING STOVE OPTION

A soot door must be provided below the flue pipe entry to allow for inspection and removal of soot and debris. A suitable wall sleeve is to be used to seal the cavity wall. Any combustible insulation within the wall must be kept away from the single skin connecting flue pipe by at least 1.5 x its diameter. (Example: diameter 150mm x 1.5 = 225mm distance).

The flue pipe is a push fit over the spigot on the adaptor. Seal off the gap between the flue pipe and wall sleeve with fire proof rope and closing plate.

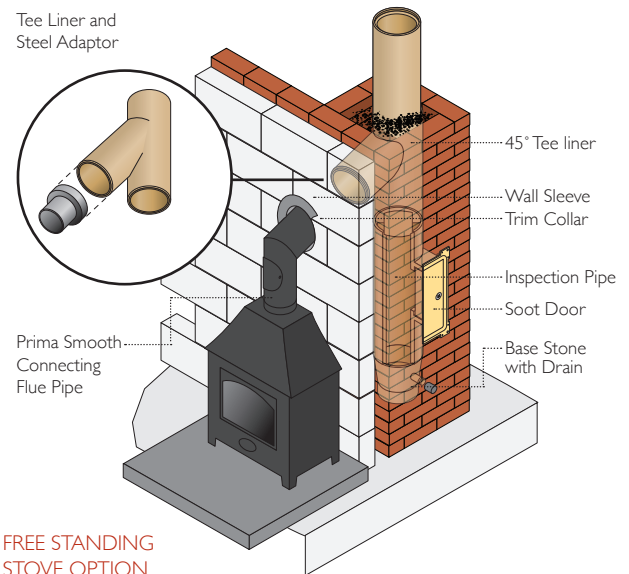

FREE STANDING STOVE OPTION

ALL OPTIONS

Apply Schiedel Rapid Cement onto the male rebate of the flue liner.

Position the flue liner on a suitably formed fire gather or support block with the female rebate facing upwards. Arrows on each flue liner indicate the directional flow of flue gases. Continue to apply high temperature cement to each flue liner, cleaning any access material from the joints.

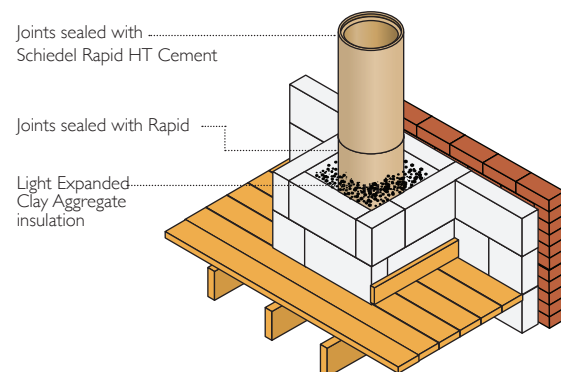

Clad the flue liners with a minimum of 100mm suitable masonry. A minimum of 15mm Leca insulation must be installed between the flue liners and masonry. Mix 20 parts Leca to 1 Part cement and a small amount of water. Ensure it is well mixed before using. (refer to table on page 3)

Installation Detail

If Bends are required in the chimney make sure adequate support is provided and always backfill with leca insulation mix. Liners can be cut between bends to achieve a required offset distance. A steel collar as well as high temperature cement must be used for any cut joints. A maximum of 2 complete offsets (4 bends) are allowed per chimney and the angle must not be greater than 45° from the vertical.

SUPPORTING AN OFFSET

The bends and liners that make up an offset must be supported adequately

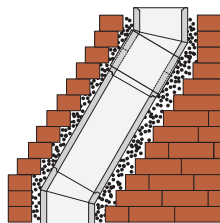

You must provide adequate clearance from combustible material in accordance with local Building Regulations. Combustible materials must be 200mm from the inner surface of flue liner or 40mm from the outside of the masonry chimney unless it is a floorboard, skirting board, dado or picture rail, mantel-shelf or architrave.

Fit appropriate lead dpc's and flashings in accordance with the relevant regulations. It is recommended that the lead tray should be dressed up the outside of the flue liners to avoid a weak joint. Weep holes should be provided above the tray for moisture drainage.

Terminate the chimney to the correct height in accordance with local Building Regulations. The chimney can be finished by flaunching (1:3 cement/sharp sand) around a suitable chimney pot. Approved rain caps can be used to help prevent water entering the flue.

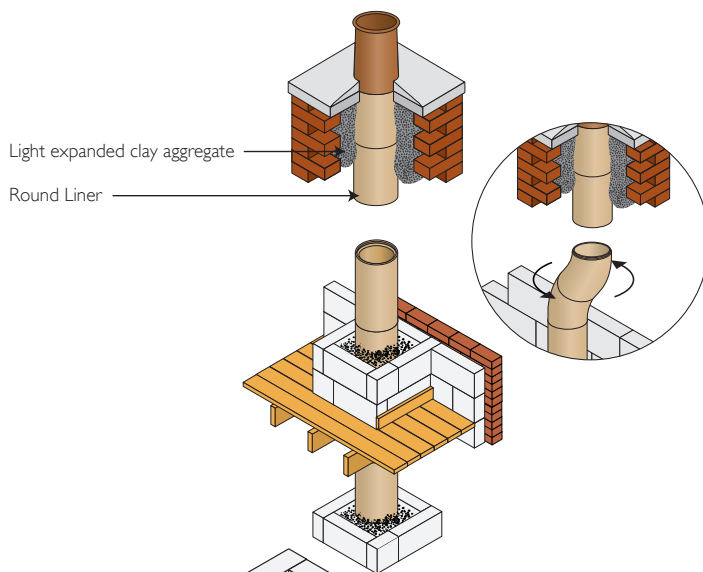
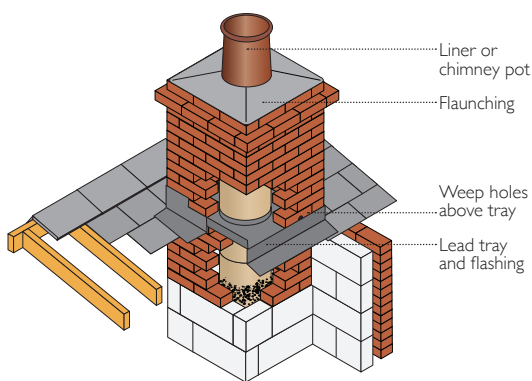

AFTER COMPLETION

After installation is complete tests and checks should be carried out in accordance with local Building Regulations. A chimney notice plate must be completed and permanently fixed in the dwelling, ideally near the electrical consumer unit. The checklist and notice plate are available from Schiedel.

USE AND MAINTENANCE

The chimney should be swept at least twice a year, once before the heating season and once after the heating season. You may need to sweep during the heating season depending upon use.

Always follow the appliance manufacturer's operating instructions. Always burn approved fuels or dry seasoned wood. Avoid burning unseasoned wood and slow burning of solid fuels as this can produce excessive soot and condensation which can in turn cause soot fires and damage. If correctly installed, operated and maintained these systems should last the life of the dwelling.

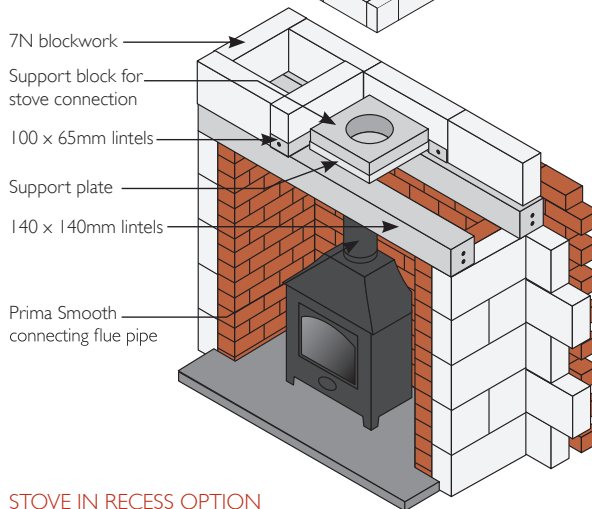

STOVE IN RECESS OPTION

Liners

Liner

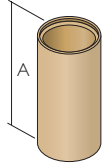

Int Ømm	160	180	200
Ext Ø	190	210	230
A	330	330	330
Weight	5.8	6.3	7.1
Pallet Qty	125	100	75
SAP Code	100374	100375	100376

30° Bend

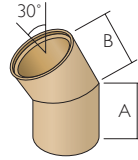

Int Ømm	160	180	200
Ext Ø	190	210	230
A	189	192	194
B	189	192	194
Weight	5.8	6.3	7.1
SAP Code	131625	131626	131627

37.5° Bend

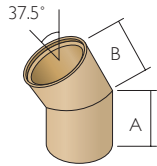

Int Ømm	160	180	200
Ext Ø	190	210	230
A	164	164	164
B	164	164	164
Weight	5.8	6.3	7.1
SAP Code	121334	121335	121336

45° Bend

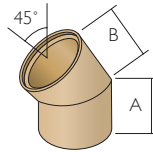

Int Ømm	160	180	200
Ext Ø	190	210	230
A	203	207	211
B	203	207	211
Weight	5.8	6.3	7.1
SAP Code	131622	131623	131624

Inspection Pipe with Inner Soot Door

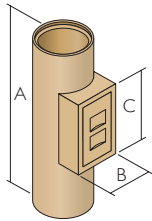

Int Ømm	160	180	200
Ext Ø	190	210	230
A	660	660	660
B	165	165	165
C	295	295	295
Weight	14	15	17
SAP Code	100428	100429	100430

Outer Soot Door

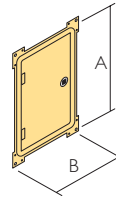

Int Ømm	160	180	200
Ext Ø	190	210	230
A	400	400	400
B	250	250	250
SAP Code	100475	100475	100475

90° Tee Liner

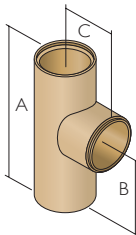

Int Ømm	160	180	200
Ext Ø	190	210	230
A	660	660	660
B	331	331	331
C	175	190	195
Weight	14	15	16
SAP Code	100420	100421	100422

135° Tee Liner

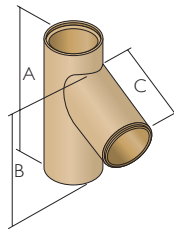

Int Ømm	160	180	200
Ext Ø	190	210	230
A	660	660	660
B	463	481	497
C	311	326	357
Weight	16	18	19
SAP Code	100424	100425	100426

Adaptor from Steel to Ceramic T Liner

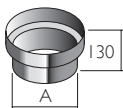

Int Ømm	160	180	200
Ext Ø	190	210	230
Ø Steel (A)	150	175	200
SAP Code	132667	132668	132669



Steel collars (for cut joints)

Int Ømm	160	180	200
SAP Code	158122	-	158123

Adaptor from Steel to Support Block

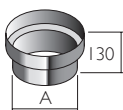

Int Ømm	160	180	200
Ext Ø	205	235	255
Ø Steel (A)	150	175	200
SAP Code	126373	126499	127691

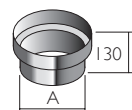

Increasing Adaptor from Steel to Support Block (with rope)

Int Ømm	160	180	200
Ext Ø	205	235	255
Ø Steel (A)	125	150	150
SAP Code	126357	126493	127671

Components

Support Blocks

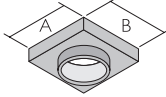

Int Ømm	150	175	200
Ext mm	310	350	350
Weight	7	8	8
SAP Code	126366	126483	127340

Support Plate

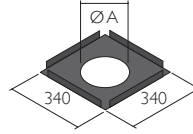

Int Ømm	160	180	200
Ext Ø	340	360	360
SAP Code	127694	128549	128549



Rapid High Temperature Joint Sealant

Size ml	310
SAP Code	100020

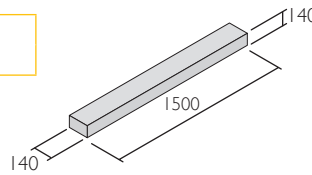

Support Lintel

Size mm	140x140
Length mm	1500
Weight kg	71
SAP Code	146431

Lintels are used in pairs to support the weight of the support block and liners as an alternative to a cast slab. On a clear span of up to 1.2m a load of up to 3250Kg can be supported.



Light Expanded Clay Aggregate Backfill Insulation (50 litre)

Size m ³	0.05
Weight kg	19
SAP Code	130769

Base Stone with Drain

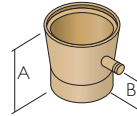

Int Ømm	160	180	200
A	170	170	170
B	70	70	70
SAP Code	102684	102685	102686

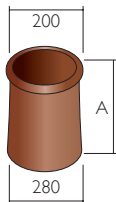

Chimney Pot (Buff and Terracotta options)

Int Ømm	150	200
A	450	450
SAP Code Buff	126370	130697
SAP Code T'cotta	126371	127341

Topguard (Buff and Terracotta options)

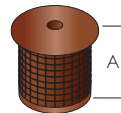

Int Ømm	150-250
A	300
SAP Code Buff	130742
SAP Code T'cotta	130737



Chimney Notice Plate

SAP Code 130696

Complementary Products and Services from Schiedel Chimney Systems



ICS

Twin Wall Insulated System Chimney for gas, oil and multi-fuel applications.

- Simple push-fit jointing system
- High efficiency Superwool insulation blanket
- Capillary break prevents moisture being drawn through the joint
- 80-300mm Diameter range



PRIMA PLUS

Single Wall Stainless Steel Flue System.

- Prima Plus available 0.6mm or 1mm options for domestic multi-fuel stoves
- Prima Plus for large residential & commercial condensing gas & oil appliances & chimney relining
- 80-300mm Diameter range



TECNOFLEX PLUS

For relining existing chimneys to take gas, oil, wood, multi-fuel appliances and open fires.

- Twin skin TecnoFlex Plus available in 316L or 904L options for oil, wood, multi-fuel & open fires
- 80-300mm Diameter range



PRIMA SMOOTH

Single Wall Stainless Steel Connecting Flue Pipe for use on wood and multi-fuel applications.

- 316L Grade stainless steel
- Available in matt black or steel finish
- Excellent aesthetics
- Lightweight
- 125-200mm internal diameters

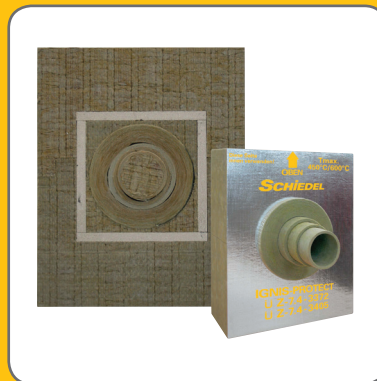

IGNIS-PROTECT

Designed specifically for Air Tight, Energy Efficient and Timber Framed Buildings

- Suitable for SW and DW connecting flue pipes passing through interior or exterior walls made of combustible materials
- Available in both 90° and 45° version



DM & LINERS

Pumice System Chimneys, Firechests and Liners.

- Pumice is a natural insulator, able to maintain the temperature of flue gases
- Lightweight - allowing one person to lift and build the chimney units
- Pumice expands and contracts less with temperature change than other chimney systems.

Schiedel Chimney Systems

Unit 8 & 9 Block A Industrial Estate,
Holton Rd,
Holton Heath,
Poole BH16 6LG
Tel. +44 (0) 1202 861650
info@schiedel.co.uk



SCHIEDEL TRAINING ACADEMY

Based in Tyne & Wear, the HETAS Approved Training Centre has a number of courses for chimney knowledge, maintenance and installation.
Visit our site, or scan the QR code for a direct link.



Visit our website

Schiedel.com/UK

Part of Standard Industries