



DEFRA
EXEMPT



Woodburning Stove System

SCHIEDEL

Reduce your reliance on gas with our woodburning stove, combined with a chimney system for a bungalow, log cabin or house.

Defra exempt for installation and use in Smoke Control Areas

www.schiedel.com/uk

SAP 00000 - January 2023



FUNCTIONAL
DESIGN

An all-in-one Stove package

Schiedel offers a unique all-in-one system: a perfect combination of DEFRA exempt stove in an easy to install package to add a stove and chimney to a newly built house or a bungalow, a self build project, or a luxury home at the drawing stage.

Our innovative and advanced clean burning technology provides an eco-friendly and pleasant warmth. Wood stoves achieve up to 84 % energy-efficiency – delivering more heat with less wood.

clearSkies

Both Schiedel Sargas models have achieved the clearSkies certification clearSkies certified

appliances meet the minimum performance level for Ecodesign regulations – the minimum legal requirement for an appliance manufactured in the UK from 1st January 2022.

These criteria are the minimum energy efficiency of the appliance and the maximum levels of emissions permitted

These new Ecodesign Regulations represent a significant tightening of these criteria over the current CE requirements.

DEFRA exempt

In addition to meeting the requirements of Ecodesign for efficiency and emissions, all clearSkies certified appliances at Level 3 or above will also have been verified by the scheme administrator as meeting the requirements for Defra exemption.

Therefore you can be assured that our Sargas models exceed the minimum requirements and are future proofed as well as approved on the Defra website to be installed in Smoke

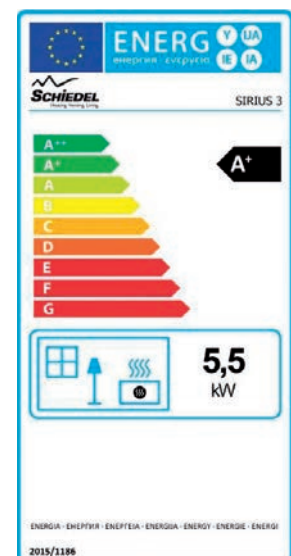
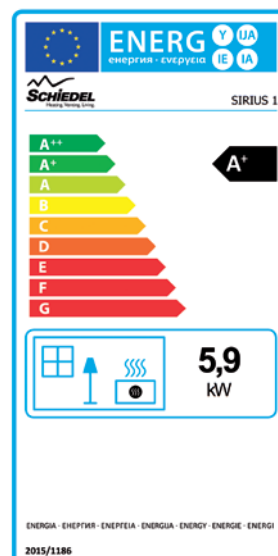

The Clean Air Act 1993 and Smoke Control Areas

Both stove models are Defra Exempt, which means they can be installed and used in Smoke Control areas.

Under the Clean Air Act local authorities may declare the whole or part of the district of the authority to be a smoke control area. The Clean Air Act 1993 and Smoke Control Areas Under the Clean Air Act local authorities may declare the whole or part of the district of the authority to be a smoke control area. It is an offence to emit smoke from a chimney of a building, from a furnace or from any fixed boiler if located in a designated smoke control area. It is also an offence to acquire an “unauthorised fuel” for use within a smoke control area unless it is used in an “exempt” appliance (“exempted” from the controls which generally apply in the smoke control area).

In England appliances are exempted by publication on a list by the Secretary of State in accordance with changes made to sections 20 and 21 of the Clean Air Act 1993 by section 15 of the Deregulation Act 2015. Similarly in Scotland appliances are exempted by publication on a list by Scottish Ministers under section 50 of the Regulatory Reform (Scotland) Act 2014. In Wales and Northern Ireland these are authorised by regulations made by Welsh Ministers and by the Department of the Environment respectively.

Further information on the requirements of the Clean Air Act can be found here at:

<https://www.gov.uk/smoke-control-area-rules>

Your local authority is responsible for implementing the Clean Air Act 1993 including designation and supervision of smoke control areas and you can contact them for details of Clean Air Act requirements. It is an offence to emit smoke from a chimney of a building, from a furnace or from any fixed boiler if located in a designated smoke control area. It is also an offence to acquire an “unauthorised fuel” for use within a smoke control area unless it is used in an “exempt” appliance (“exempted” from the controls which generally apply in the smoke control area).

In England appliances are exempted by publication on a list by the Secretary of State in accordance with changes made to sections 20 and 21 of the Clean Air Act 1993 by section 15 of the Deregulation Act 2015. Similarly in Scotland appliances are exempted by publication on a list by Scottish Ministers under section 50 of the Regulatory Reform (Scotland) Act 2014. In Wales and Northern Ireland these are authorised by regulations made by Welsh Ministers and by the Department of the Environment respectively.

Further information on the requirements of the Clean Air Act can be found here at:

<https://www.gov.uk/smoke-control-area-rules>

Your local authority is responsible for implementing the Clean Air Act 1993 including designation and supervision of smoke control areas and you can contact them for details of Clean Air Act requirements.



Sargas stove system advantages

Stove-highlights

Heat sustainably and  neutrally with local firewood, independent of international electricity, gas and oil suppliers.

Thanks to high-quality manufacturing and optimal combustion chamber construction, the SARGAS oven offers high energy efficiency: Class A+ environmentally friendly combustion tested according to DIN EN 13240

Simple, air-cooled door handle and self-closing door

Simple operation with one lever for both primary and secondary combustion air

Adjustable legs for uneven floors

System highlights

Combustion air independent from installation room, provided through perimeter smooth air chimney from top, allows flexible placement

Due to system solution, no separate air channel adaptor/ bypass necessary.

- Ideal for timber frame buildings such as log cabins
- Exceptional small distances to combustibles



Stove specifications / approvals

Stove name:	Sargas 1 and Sargas 3
Standard:	EN 13240 RRF – 40 17 4674
Rated output:	6.2 kW
Efficiency:	81 %
Emissions:	CO ₂ (at 13% O ₂) 1125 mg/m ³
Emissions:	dust 6 mg/m ³
Flue gas temperature:	327 °C
Negative pressure in the chimney:	12 Pa
Weight (depends on the stove type)	approx.100 kg
Stove dimensions	W x D x H 526 mm x 417 mm x 1133,7 mm
Minimum distance from combustible materials	front 1050 mm / sides 400 mm and back 200 mm lateral Sargas 3: 400 mm
Allowed fuel consumption	2 kg/h



DEFRA EXEMPT

The Sargas is DEFRA exempt so it can be installed and used in Smoke Control Areas in the United Kingdom, when operated in accordance with the instruction and installation manuals and when any conditions are



CLEARSKIES LEVEL 5

Both Sargas models have achieved the clearSkies certification, which means that they exceed the

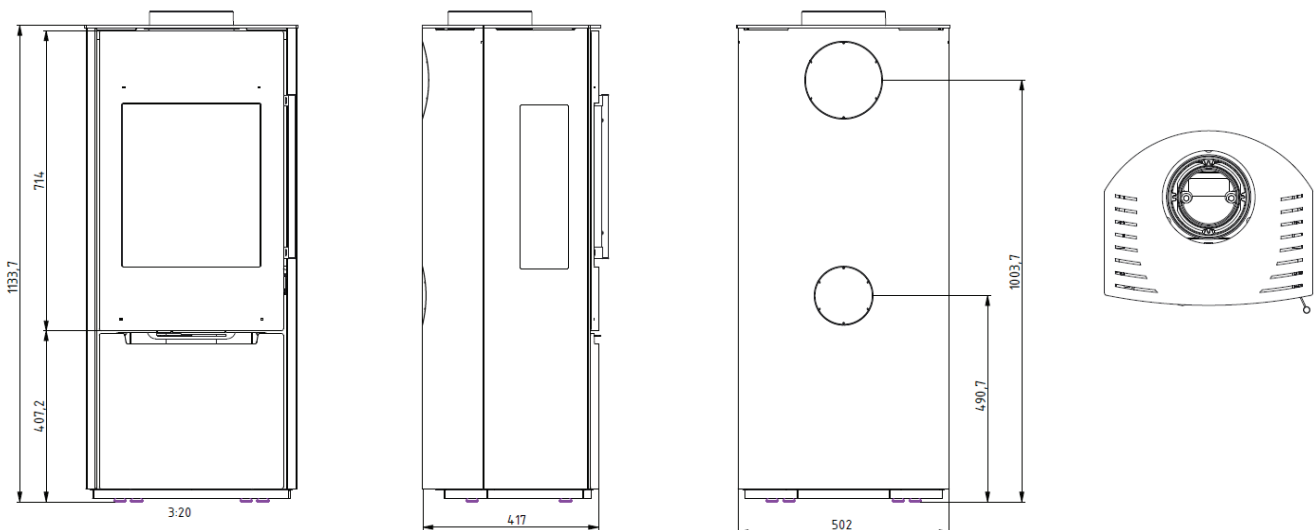

Chimney system

Twin wall steel chimney offers great flexibility and flexible placement

The twin wall chimney system with a quick jointing system. It is used for wood burning.

The components have a twin wall construction with a male spigot and a female socket to provide simple and rapid installation.

With its fully sealed components, the twin wall system can be installed both internally and externally. The system is supplied with a ten year conditional warranty.

WALL	Sargas1	Sargas 3
FRONT	1050mm	
SIDE	400mm	
BACK	200mm	
LATERAL		400mm



For distances to combustibles from the chimney, or chimney through floor or shaft, please refer to the guide for the twin wall chimney system provided.

From a combustible wall

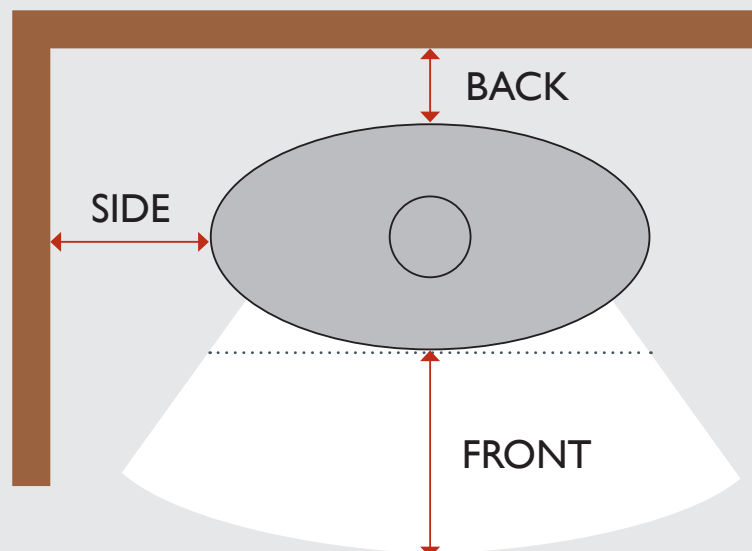

System overview - Vantage*

Technical characteristics

Application	Chimney/Flue system			
Operating mode	Dry			
Pressure	Negative pressure			
Operating Temperature	450 °C / 600 °C			
Thermal Shock	1000 oC [max 30 min]			
Inner Wall	material	AISI 316L/EN 1.4404		
	thickness	0.5 mm		
Outer wall	material	AISI 304 BA/EN 1.4301		
	thickness	0.5 mm		
Insulation	type	Mineral wool		
	thickness	25 mm		
Fuel Type	Wood/Gas/Oil/Approved Solid Fuels			
ID mm	125(5")	150(6")	175(7")	200(8")
OD mm	175	200	240	250
Cross section cm ²	123	177	241	314
Weight ±kg/m	5.5	6.5	7.5	8.0

Chimney diameter

The chimney size should be as recommended by the appliance manufacturer. Where there is a requirement for a flue diameter smaller than the appliance spigot, then the operational requirements of the appliance and the configuration of the flue must satisfy the flue sizing requirements of EN13384—1 for single appliances.

CE approved

EN1856: T450 N1 D V3 L50050 G50 [in free air]

EN1856: T450 N1 D V3 L50050 G60 [in a combustable shaft with ventilated fire stops]

EN1856: T600 N1 D V3 L50050 G100 [in a combustable shaft with ventilated fire stops]

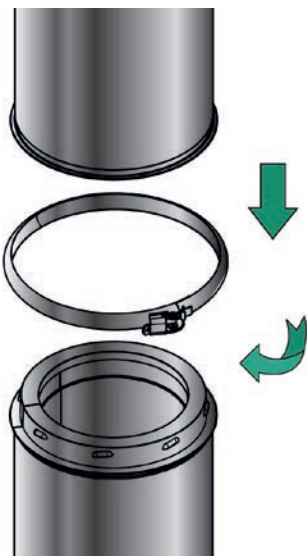

Joint design and construction

The joint is made by fitting the female end over the male end and engaging the joint system by rotating the component clockwise. A locking band is then fitted to secure the joint, as shown. The Vantage joint incorporates an eight barb twist lock coupler system to allow easy and rapid installation of the product.

***note that a compatible twin wall system can also be supplied and used with the correct adaptor.**

Prior to installation

Mandatory requirements

The system must be installed according to valid British/European Standards, national building regulations and Schiedel Installation Instructions **of the manufacturer as indicated in the documentation.**

Apart from the general instructions there are specific instructions in connection with the type of connected Wood appliance. Always refer to appliance installation instructions and related standards covering specific applications!

Chimney diameter

The chimney size should be as recommended by the appliance manufacturer. The operational requirements of the appliance and the configuration of the flue must satisfy the flue sizing requirements of EN13384-1 for single appliances.

Appliance-chimney connection

When connecting the appliance directly to a system chimney, the appropriate appliance connector must be used and the joint between the appliance spigot and the appliance connector must be securely caulked and sealed with non asbestos rope or suitable alternative. The connection to the appliance should be carried out only by a competent person.

Chimney route

The chimney should remain as straight as possible through its vertical run to assist flow. Before installing the chimney be sure that there are no beams or rafters mounted in the chimney vertical run.

Enclosure/Shaft

With the exception of the room containing the appliance, where the chimney passes through any part of the building where there is a risk of accidental human contact, i.e. a bedroom etc., or where there is a risk of contact with combustible materials, the chimney should be enclosed in an appropriate way. Please check requirements in national building and fire regulations. This can be achieved by boxing in the chimney in habitable rooms, or by the use of a protective wire mesh frame in roof spaces etc. In all cases the minimum distance to any combustible material, including loft insulation, must be respected and any enclosure should meet the requirements of national building and fire regulation.

Inspection openings

According to national regulations, provisions should be made to enable a chimney to be inspected and cleaned. Respective national building code and requirements of appropriate standards should be observed. We recommend consulting a competent chimney sweep on the arrangement of the inspection opening. To aid cleaning, sufficient distance should be left between changes of direction to permit the safe passage of cleaning brushes within the system.

Distance to combustibles

On Wood applications, where there is a risk of soot fire, it is essential that the correct distance to combustible material is maintained.

Please refer to the twin wall chimney system guide on distance to combustibles.

System design guide

Loading bearing Information

A	Max. installation height from base or intermediate support	8 m
B	Max. distance between lateral supports	3 m
C	Max height above last support	2 m
X	Max offset distance between 2 bends	1 m

Support components

Prior to installation the number and position of support components should be established according to the load bearing information and max. allowed distances between supports.

The weight of a chimney system requires an independent support. Only minimal weight should be borne by the appliance (e.g. vertical connecting flue section, up to the floor passage). The chimney can be supported from floor level by using a telescopic rear support, or from first floor level by using a ceiling box fixed between two ceiling joists. In longer vertical runs wall bands should be used to support the chimney, fixed to the wall/roof structure.

They can be used in combination with the wall band extension components to provide for adjustment to various distances from the wall. Wall bands are non-load bearing and provide lateral support only.

Terminals

Terminals are supplied complete with a locking band. Once the terminal has been pushed into place, the adjustment bolts on the locking band clips should be tightened to ensure that the terminal is properly secured to the previous pipe.

Free standing height above the roof

Max free standing height is 2m. Where height is >600mm above the last structural support, a locking band is required immediately below the roof support and on any pipe joints above it. Where the free-standing height should exceed 2,0 m above the last support or above the roof, a guy wire bracket must be used in conjunction with guy wires or rigid stays.

Lightning protection

Stainless steel flue gas system can be damaged by a lightning strike. If a building has a lightning conductor or earthing circuit make sure that flue gas system is incorporated to it.

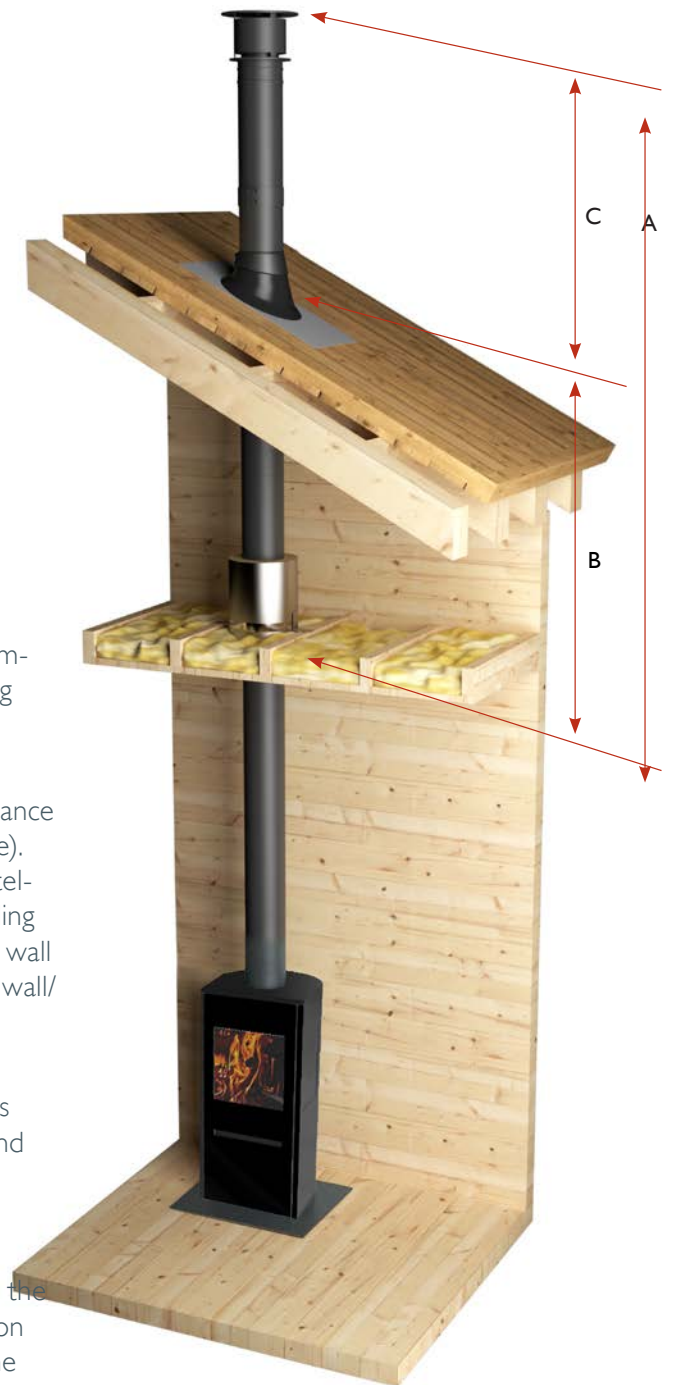

Maximum offset info.

Int Ø	150
X (m)	1
Y (m)	1

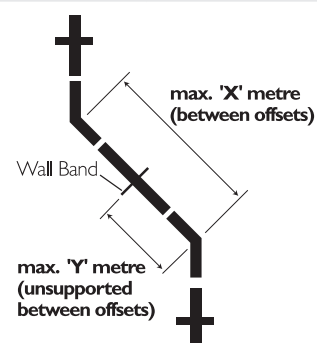

Outlet siting

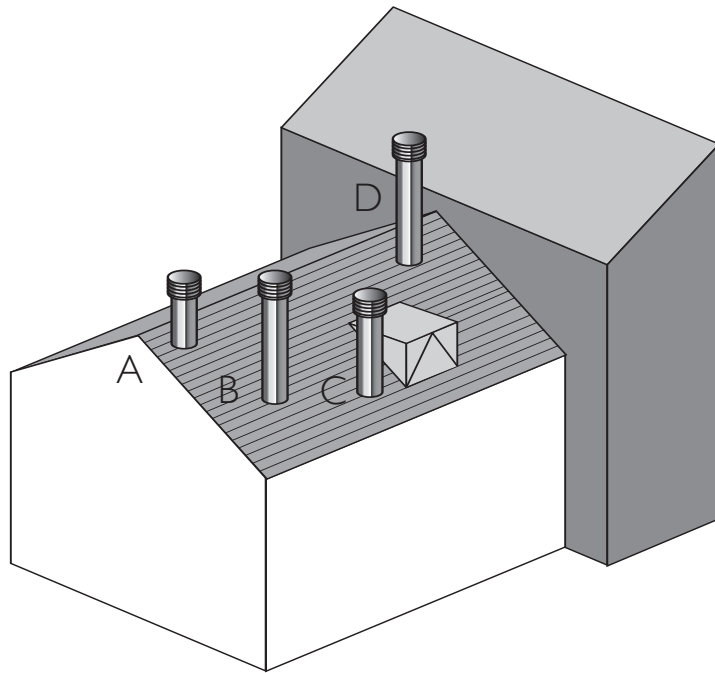

Point where flue passes through weather surface (Notes 1, 2)		Clearance to flue outlet
A	At or within 600mm of the ridge	At or within 600mm above the ridge
B	Elsewhere on the roof (whether pitched or flat)	At least 2300mm horizontally from the nearest point on the weather surface and: a) at least 1000mm above the highest point of intersection of the chimney and the weather surface; or b) at least as high as the ridge
C	Below (on a pitched roof) or within 2300mm horizontally to an openable roof-light, dormer window or other opening (Note 3)	At least 1000mm above the top of the opening

Delivery to site and storage

Components should be carefully transported and off loaded. Ensure all chimney components are available and check them to ensure there has been no damage. Components should be stored and protected on site from accidental damage. Do not use damaged components!

Handling

It is advised that suitable personal protective equipment should be used when handling the products. Use only

Installation instructions



1. Make sure the outlet on the stove is installed correctly, according to the installation manual for the stove. Apply high temperature liquid sealant on the inner and outer ring of the stove outlet to provide a gas tight connection.



2. Place the adapter and push the protruding liner onto the stove connector. If necessary, the adapter can be cut at the bottom to get the desired distance between the pipe and the stove top plate.

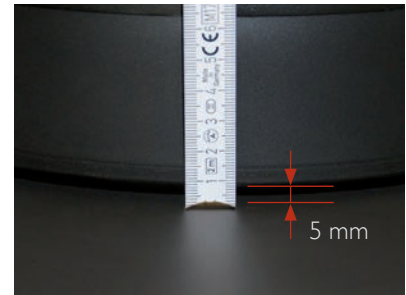

3. The outer case of the adapter should not be in direct contact with the top plate of the stove. There should be at least 5 mm clearance ensured.

The weight of a chimney system is considerable and requires independent support. Minimal weight should be borne by the appliance or concentric stove connector. Please refer to section » passage through the floor for further reference.

Installation – which way up?

All flue gas carrying components must be installed with the direction arrow on the product label pointing to ter-

Joining system

Joints in the twin wall system are made by means of a simple push fit, or twist lock joining method.

Thermal expansion

All twin wall elements are designed to allow for thermal expansion of the liner within each joint, so there is no requirement for any additional expansion joints.

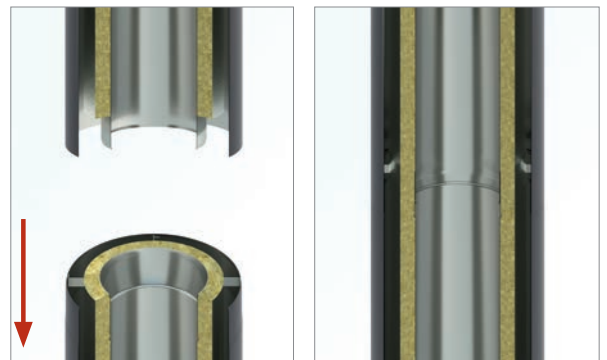

Install first chimney inspection pipe with test point depending on the height of the floor a proper pipe length should be used to span the distance between the stove adapter and a ceiling box installed to the bottom level of the floor level above.

Inspection

To conform to Building Regulations, an inspection length must be used directly above the appliance adaptor to allow for cleaning access. To aid cleaning, sufficient distance should be left between changes of direction to permit the safe passage of cleaning brushes within the system. This is particularly important on Wood applications. It is recommended that chimneys serving Wood appliances be swept as frequently as necessary, but at least twice a year.

Support components

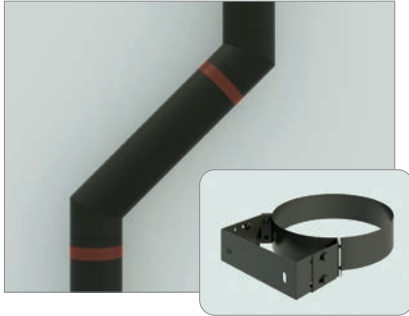

Offset (optional)

In most cases, pipes are installed vertically from bottom to top, but conflict with roof rails or alike can occur, so an offset should be used to avoid obstacle. Check national regulation on required inspection openings when installing offsets to assist cleaning.

A locking band should be mounted on each joint to strengthen installed length. Wall bands should be installed in locations as shown in the picture to support stability of the



Wall bands

Wall bands are non load bearing and provide lateral support only. They are used in intermediate chimney sections where non supported chimney length exceed max. allowed lengths. Refer to the load bearing tables on page 10 for full

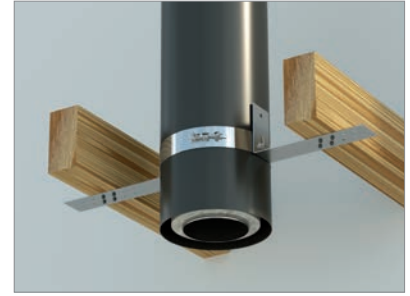

Passage through the roof

Roof structure represent the upper most position for fixing the chimney before transition to the free standing part. We recommend using a roof support bracket which is supplied as a kit, complete with two side plates for fixing to the roof trusses and a band to give lateral support to the chimney as it passes through the roof. Special attention should be drawn to distance to combustible between the outer

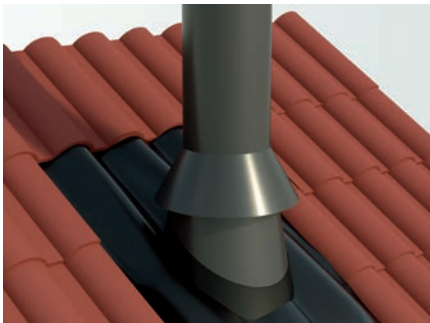

Section above the roof

A chimney penetration should be protected accordingly. We recommend

For external applications (above the roof) a bead of silicone may be applied.

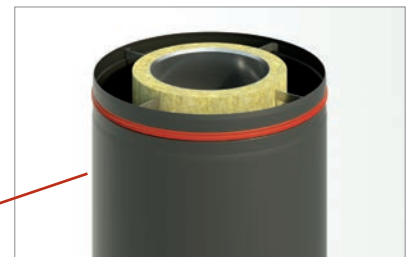

Bead of silicone sealant to be applied on external pipes.

Protect Box through a roof.

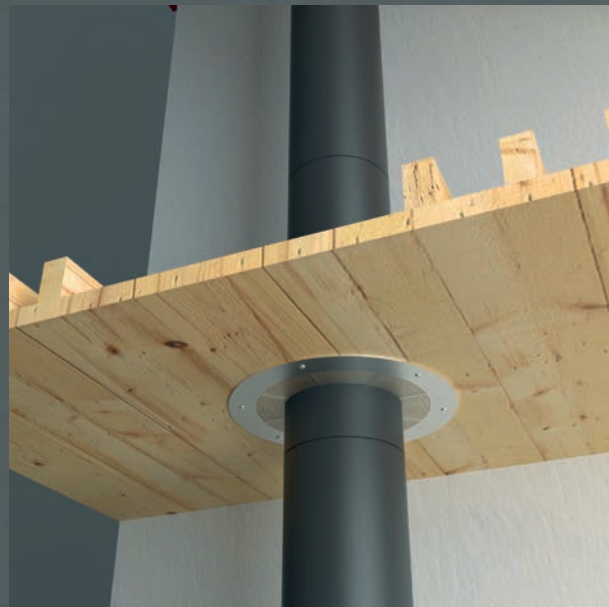
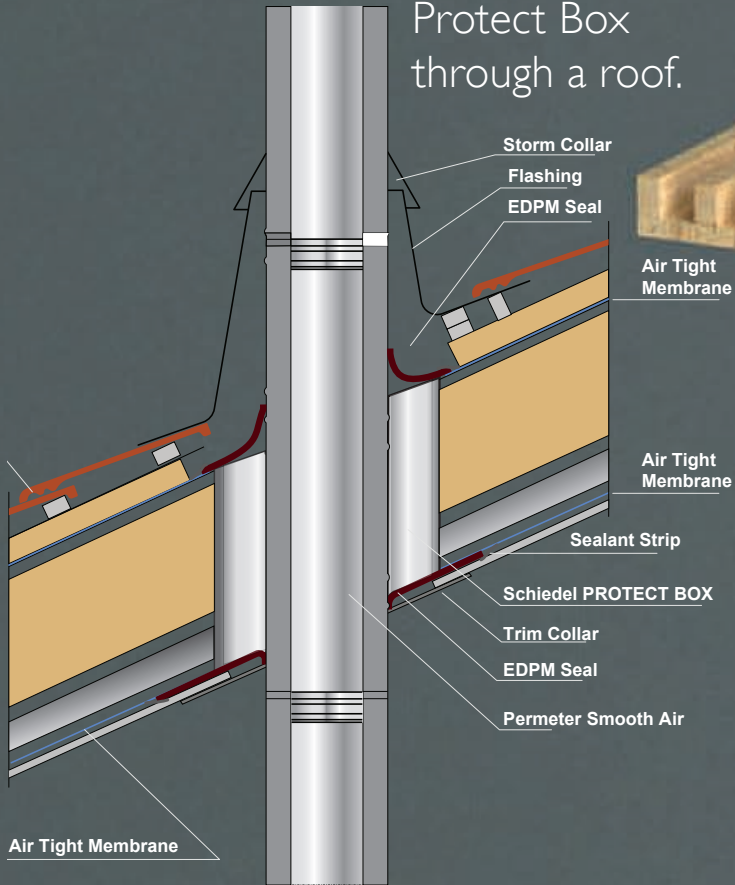

Support detail using ventilated firestops and ventilated support plates.

A ventilated firestop is used on the living room ceiling with a ventilated support plate at first floor level.

A ventilated firestop is used in the bedroom ceiling and then a Protect Box can be used at roof level together with EPDM mats to maintain an air tight envelope within the building



Support Components



Structural locking band

A structural locking band (supplied separately) should be used in sections above the roof where structural support is required. Max free standing height is 2m. Where height is >600mm above the last structural support, a locking band is required immediately below the roof support and on any pipe joints above it.



Guy wire bracket

Where the free-standing height should exceed 2,0 m above the last support or above the roof, a guy wire bracket must be used in conjunction with guy wires or rigid stays. Please contact Schiedel technical service for advice on details of installation.

Terminal

The terminal used is designed to ensure sufficient air supply to the stove, which has been approved.



After Installation

CE chimney plate

After installation a chimney plate must be applied. This is the responsibility of the installer.

Maintenance and cleaning

Chimneys should be regularly inspected and cleaned according to the national chimney sweep regulation. Only stainless steel or plastic brushes are allowed to be used for cleaning to avoid corrosion on the flue liner.

Carbon monoxide detector

It is essential that a Carbon monoxide detector is installed in room or dwelling where a Wood appliance is installed. This should comply with EN 50291.

Please follow manufacturer's instructions with regards to siting and fixing on the ceiling at least 300 mm from any wall or if it is located on a wall, as high up as possible (above any doors and windows), but not within 150 mm of the ceiling between 1 m and 3 m horizontally from the appliance

N.B Provision of a carbon monoxide detector should not be regarded as a substitute for correct installation and

Heating with wood



Renewable resource

Wood is a renewable resource that burns only as much carbon dioxide (CO₂) as it releases from natural decomposition in the forest or as much as the tree captured from the atmosphere during its growth.

High energy value

Firewood has a high energy value. For example, take oak: whilst it has a residual wood moisture content of approx. 15–20%, its calorific value adds up to 4.2 kWh per kilogram.

9% (2020)



13-15% (2035)

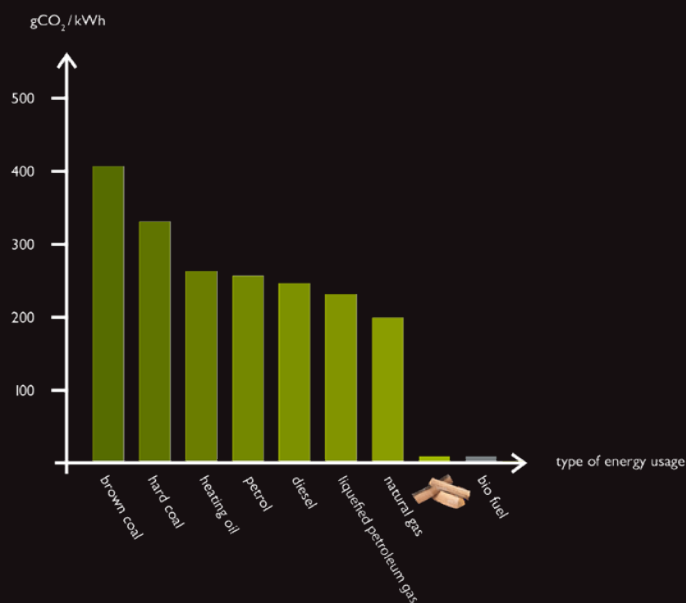

Low emission factor

The impact of air pollution on our health and environment is so significant that it is considered to be the second biggest environmental concern after climate change.

Firewood has a low emission factor in comparison with other energy sources, with a very low primary energy coefficient of 0.2.

European forest is growing

30% of annual forest growth remains in the forest. The area of European forests is increasing by the size of a football field every minute, increasing the potential for carbon capture in the coming decades.

30% of the annual forest increment remains in the forest.



The spark in all of us

SCHIEDEL

The spark in all of us is an internal north star and constant driver of all our ideas and actions. An irrepressible force of nature that constantly pushes us forward and helps us to leave old things behind.

It is the source of our inspiration to make things better, smarter, more sustainable and stay ahead of the game. The spark of our inspiration also jumps over to the people we deal with: our partners, our customers.

THE SPARK

STANDARD-SETTER

We spark tomorrow's industry standards & trends.

PASSIONATE

New ideas for future buildings are constantly sparked by our ingrained passion for smarter, more liveable, sustainable solutions.

CARING

We value and nurture the spark that our people carry and how they transfer it over to our customers.

PARTNERSHIP-ORIENTED

We pro-actively seek our customers feedback to let their needs spark inspiration for new technical solutions and services.

A **standard**
INDUSTRIES COMPANY



Schiedel Chimney Systems
Crowther Estate, Washington
Tyne & Wear NE38 0AQ
Tel. +44 (0)191 416 1150

sales.uk@schiedel.com
schiedel.com/uk



Follow us on Social Media @SchiedelUK



A **standard**
INDUSTRIES COMPANY