



DEFRA
EXEMPT



Sirius Stove System



Complete Ecodesign stove and concentric, air-tight chimney flue system for a bungalow, log cabin or house.

Approved for installation and use in Smoke Control Areas



FUNCTIONAL DESIGN

DEFRA EXEMPT The Sirius is approved for use in Smoke Control Areas in the United Kingdom, when operated in accordance with the instruction and installation manuals and when any conditions are met.

An all-in-one Stove package

Schiedel offers a unique all-in-one system: a perfect combination of DEFRA exempt stove in an easy to install package to add a stove and chimney to a newly built house or a bungalow, a self build project, or a luxury home at the drawing stage.

Our innovative and advanced clean burning technology provides an eco-friendly and pleasant warmth. Wood stoves achieve up to 84 % energy-efficiency – delivering more heat with less wood.

clearSkies

Both Sirius models have achieved the highest level in clearSkies certification



clearSkies certified appliances meet the minimum performance level for Ecodesign regulations – the minimum legal requirement for an appliance manufactured in the UK from 1st January 2022.

These criteria are the minimum energy efficiency of the appliance and the maximum levels of emissions permitted

These new Ecodesign Regulations represent a significant tightening of these criteria over the current CE requirements.

DEFRA exempt

In addition to meeting the requirements of Ecodesign for efficiency and emissions, all clearSkies certified appliances at Level 3 or above will also have been verified by the scheme administrator as meeting the requirements for Defra exemption.

Therefore you can be assured that our Sirius 1 and Sirius 3G models exceed the minimum requirements and are future proofed as well as approved on the Defra website to be installed in Smoke Control Areas

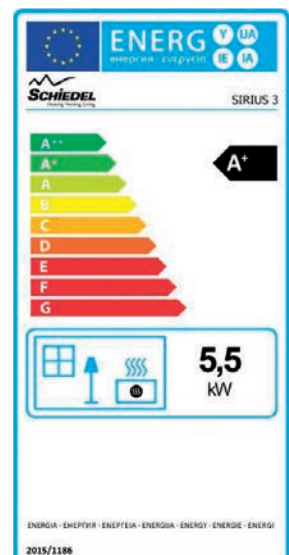
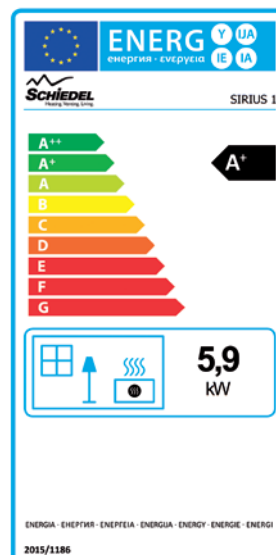

Wood burning stove system

Sirius 1 and 3G



SIRIUS 1
Large front window



SIRIUS 3G
Large glass front window and door
and additional side windows for
180° degree view.

- 1 Only one lever for regulating primary and secondary air.
- 2 Elegant powder coated combustion-door handle staying cool and clean.
- 3 Comfortable woodbox compartment with front door.
- 4 The touching point to open the door is marked with powder coated circle, preventing scratches in the varnish.



Sirius stove system advantages

STOVE-HIGHLIGHTS

Highly efficient up to 84%! More heat, less wood

Highest European and National Standards - EN 13 240, DIN+, 1.BImSchV2, DiBt, 15a B-VG, NS 3058/3059

Easy to operate with Self closing door and interlock system for igniting or cleaning purpose

3 Windows for 180° view in the 3G model

Eco-friendly corpus paint resulting in environmentally friendly low smoke and low emission colour

Adjustable legs to adapt to uneven surfaces

SYSTEM HIGHLIGHTS

Combustion air independent from installation room, provided through Perimeter Smooth Air Chimney from top, allows flexible placement

Due to system solution, no separate air channel adaptor/ bypass necessary.

IDEAL FOR TIMBER FRAME BUILDINGS SUCH AS LOG CABINS

Ceiling Box and Protect Box options for complete safety in timber framed buildings.

Exceptional small distances to combustibles



Specifications / Approvals

	SIRIUS 1	SIRIUS 3G
Width	512mm	512 mm
Height	1218mm	1218 mm
Depth	392mm	392 mm
Output	5,9 kW	5,5 kW
Efficiency	84%	82 %
Energy Efficiency	A+	A+
Weight	164 kg	172 kg
Air Independent	✓	✓
Triple-Air-Connection	✓	✓

APPROVALS	
EN 13 240	✓
DIN+, BImSchV 2, CE	✓
15a B-VG	✓
NS 3058 / 3059	✓
DEFRA EXEMPT	✓
CLEARSKIES LEVEL 5	✓



DEFRA EXEMPT

The Sirius is DEFRA exempt so it can be installed and used in Smoke Control Areas in the United Kingdom, when operated in accordance with the instruction and installation manuals and when any conditions are met.



CLEARSKIES LEVEL 5

Both Sirius models have achieved the highest level in clearSkies certification, which means that they exceed the minimum performance level for Ecodesign Regulations.

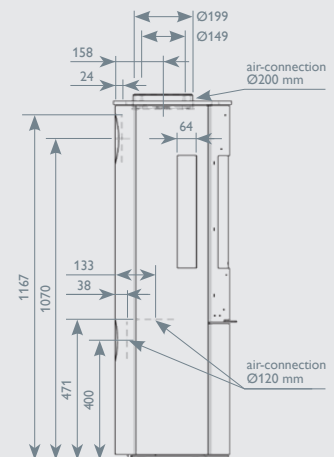
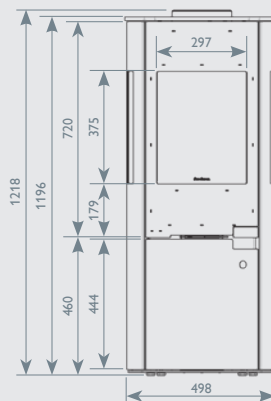
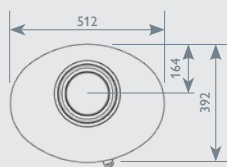
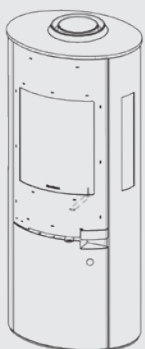

Permeter Smooth Air chimney system

Steel chimney with air supply offers great flexibility and flexible placement

All Sirius models are approved by the highest European standards for air independent use (Germany). This allows the combined usage with ventilation systems in modern buildings and guarantees a healthy indoor environment.

Schiedel Permeter Smooth Air chimney is constructed with a separate inlet-duct ¹ ensuring that the stove is supplied with the optimal amount of combustion air from the top of the pipe. The double insulated pipes avoid condensation.

The chimney system can be delivered with 45 degrees bends, L-tubes and T-tubes ² to achieve best placement flexibility of the stove.



DISTANCES TO COMBUSTIBLES		SIRIUS 1	SIRIUS 3G
A	With Permeter Smooth Air System	50mm	70 mm
B	With Permeter Smooth Air System	220mm	600 mm
B1	With Permeter Smooth Air System	150mm	–
C	Distance from Glass	1000mm	1100mm
C	Distance from Superimposed Hearth	225mm	225mm
D	Distance to Non Combustible Wall	50mm	50mm
E	Distance from Non Combustible Wall	100mm	200mm

For distances to combustibles from the chimney, or chimney through floor or shaft, please refer also to page 9

Exceptional small distances to combustibles in combination with Permeter Smooth Air Chimney.

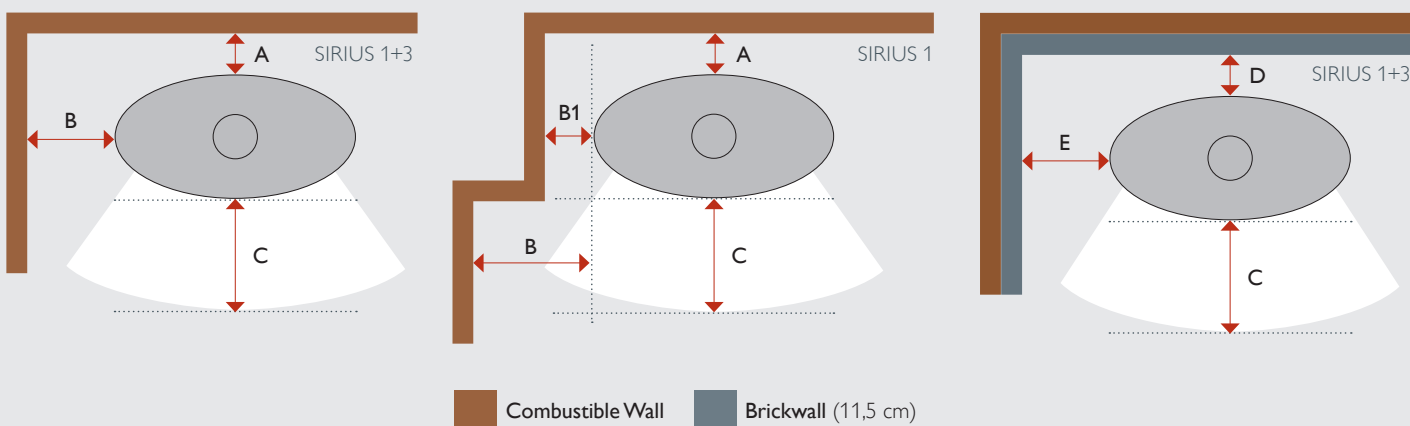

System overview

Product description	Modular, concentric flue system for operation with room sealed Wood appliances with continuous operating temperature up to 600 °C.
Installation	Inside a building
Fuel	Wood
Operating temperature	≤ 600 °C
Mode of operation	- negative pressure (N1 ≤ 40 Pa) - dry
Inner pipe material	EN 1.4521 (AISI 444)
Outer case material	- galvanized steel, powder painted - 1.4301 (304) stainless steel
Outer case finish	- black (RAL 9005) - grey (RAL 7043S) - white (RAL 9003S) - brushed (with 1.4301 material)
Insulation type	PMSA 25: 25 mm thick mineral wool tube, with aluminium lamination.
Insulation density	128 kg/m ³
Thermal resistance	PMSA 25 = 0,37 m ² K/W
Mean roughness	1,0 mm according to EN 13384-1
Height above last structural support	2,0 m with locking bands – first installed below the last support
Distance between lateral supports	3,0 m

CE Certificate number EN 1856-1:	CE Designation EN 1856-1:
0036 – CPR – 91236 – 034	T400 N1 D V3 L50050 G75 With Ceiling Box and Protect Box with in Bungalow
0036 – CPR – 91236 – 034	T400 N1 D V3 L50050 G100 With Ventilated Firestop Plate in a combustible shaft with combustible floors

PERMETER SMOOTH AIR 25	
Internal diameter:	150 mm
External diameter:	250 mm
Inner liner thickness:	0,6 mm
Outer wall thickness:	0,6 mm
Weight:	7,7 kg/m

Prior to installation

Mandatory requirements

The PMSA system must be installed according to valid British/European Standards, national building regulations and Schiedel Installation Instructions of the manufacturer as indicated in the documentation.

Apart from the general instructions there are specific instructions in connection with the type of connected Wood appliance. Always refer to appliance installation instructions and related standards covering specific applications!

Chimney diameter

The chimney size should be as recommended by the appliance manufacturer. The operational requirements of the appliance and the configuration of the flue must satisfy the flue sizing requirements of EN13384-1 for single appliances.

Appliance-chimney connection

When connecting the appliance directly to a system chimney, the appropriate appliance connector must be used and the joint between the appliance spigot and the appliance connector must be securely caulked and sealed with non asbestos rope or suitable alternative. The connection to the appliance should be carried out only by a competent person.

Chimney route

The chimney should remain as straight as possible through its vertical run to assist flow. Before installing the chimney be sure that there are no beams or rafters mounted in the chimney vertical run.

Enclosure/Shaft

With the exception of the room containing the appliance, where the chimney passes through any part of the building where there is a risk of accidental human contact, i.e a bedroom etc., or where there is a risk of contact with combustible materials, the chimney should be enclosed in an appropriate way. Please check requirements in national building and fire regulations. This can be achieved by boxing in the chimney in habitable rooms, or by the use of a protective wire mesh frame in roof spaces etc. In all cases the minimum distance to any combustible material, including loft insulation, must be respected and any enclosure should meet the requirements of national building and fire regulation.

Inspection openings

According to national regulations, provisions should be made to enable a chimney to be inspected and cleaned. Respective national building code and requirements of appropriate standards should be observed. We recommend to consult competent chimney sweeper on the arrangement of the inspection opening. To aid cleaning, sufficient distance should be left between changes of direction to permit the safe passage of cleaning brushes within the system.

Distance to combustibles

On Wood applications, where there is a risk of soot fire, it is essential that the correct distance to combustible material is maintained. Perimeter Smooth Air is available with two different insulation thicknesses where these versions have different required distance to combustibles.

PERMETER SMOOTH AIR 25		
Temperature rating:	T400 Protect Box	T400 Ventilated Firestops
Installed fully ventilated:	75 mm	100mm
Installed through insulated floor/roof H ≤ 200 mm:	75 mm	100mm

System design guide

Loading bearing Information

A	Max. installation height from base or intermediate support	8 m
B	Max. distance between lateral supports	3 m
C	Max height above last support	2 m

Support components

Prior to installation the number and the position of support component should be established according to the load bearing information and max. allowed distances between supports.

The weight of a chimney system requires an independent support. Only minimal weight should be borne by the appliance (e.g. vertical connecting flue section, up to the floor passage). The chimney can be supported from floor level by using a telescopic rear support, or from first floor level by using a ceiling box fixed between two ceiling joists. In longer vertical runs wall bands should be used to support the chimney, fixed to the wall/roof structure.

They can be used in combination with the wall band extension components to provide for adjustment to various distances from the wall. Wall bands are non-load bearing and provide lateral support only.

Terminals

All terminals must be secured with the use of a locking band. On Wood appliances, an open termination is normally recommended. However in certain conditions, rain caps or anti-down-draught terminals may be used. Terminals are supplied complete with a locking band. Once the terminal has been pushed into place, the adjustment bolts on the locking band clips should be tightened to ensure that the terminal is properly secured to the previous pipe.

Free standing height above the roof

A height of up to 2,0 m can be achieved unsupported using locking bands at the joint immediately below the last support and on every joint above it. Where the freestanding height should exceed 2,0 m above the last support or above the roof, a guy wire bracket must be used in conjunction with guy wires or rigid stays.

Lightning protection

Stainless steel flue gas system can be damaged by a lightning strike. If a building has a lightning conductor or earthing circuit make sure that flue gas system is incorporated to it.

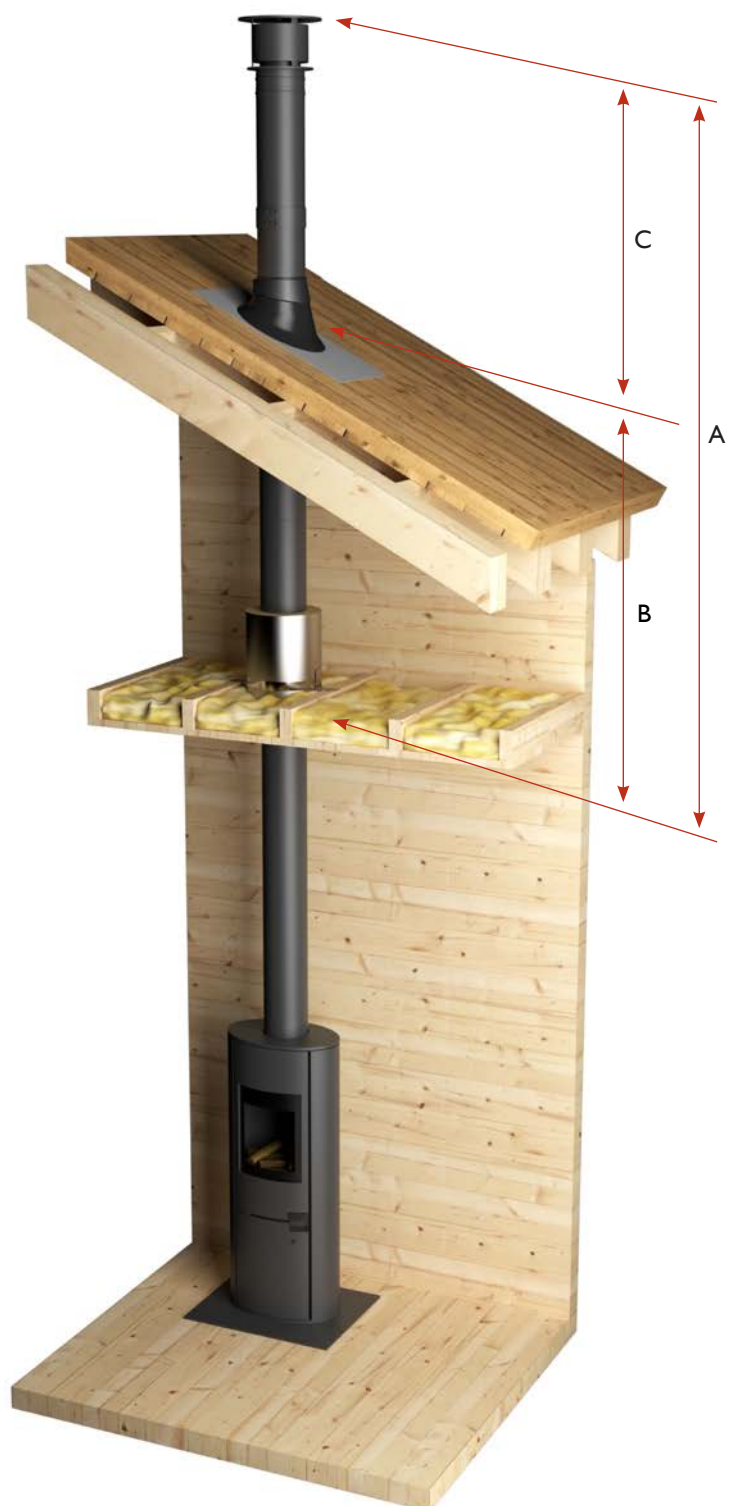

Outlet siting

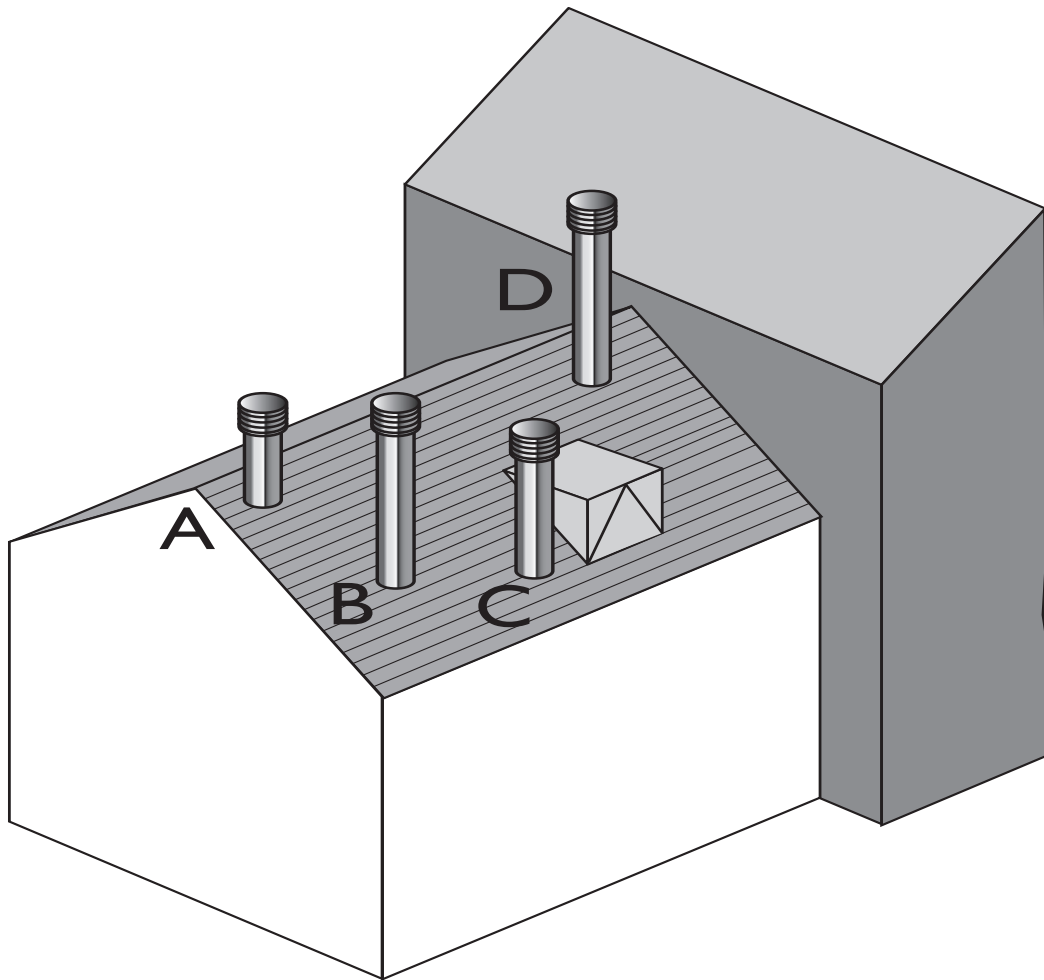

	Point where flue passes through weather surface (Notes 1, 2)	Clearance to flue outlet
A	At or within 600mm of the ridge	At or within 600mm above the ridge
B	Elsewhere on the roof (whether pitched or flat)	At least 2300mm horizontally from the nearest point on the weather surface and: a) at least 1000mm above the highest point of intersection of the chimney and the weather surface; or b) at least as high as the ridge
C	Below (on a pitched roof) or within 2300mm horizontally to an openable roof-light, dormer window or other opening (Note 3)	At least 1000mm above the top of the opening
D	Within 2300mm of an adjoining or adjacent building, whether or not beyond the boundary (Note 3)	At least 600mm above any part of the adjacent building within 2300mm

Delivery to site and storage

Components should be carefully transported and off loaded. Ensure all chimney components are available and check them to ensure there has been no damage. Components should be stored and protected on site from accidental damage. Do not use damaged components!

Handling

It is advised that suitable personal protective equipment should be used when handling the products. Use only clean gloves! Stainless steel components may only be processed with stainless steel tools!

Installation instructions

Appliance connection



1. Make sure the concentric outlet on the stove is installed correctly, according to the installation manual for the stove. Apply high temperature liquid sealant on the inner and outer ring of the stove outlet to provide a gas tight connection.



2. Place the concentric adapter and push the protruding liner onto the stove connector. If necessary, the adapter can be cut at the bottom to get the desired distance between the pipe and the stove top plate.

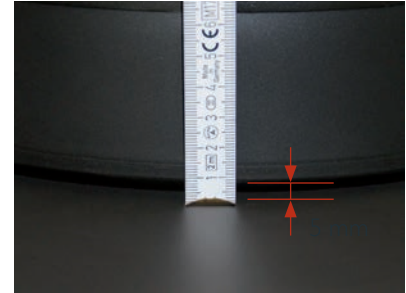

3. The outer case of the adapter should not be in direct contact with the top plate of the stove. There should be at least 5 mm clearance ensured.

The weight of a chimney system is considerable and requires independent support. Minimal weight should be borne by the appliance or concentric stove connector. Please refer to section » passage through the floor for further reference.

Installation – which way up?

All flue gas carrying components must be installed with the direction arrow on the product label pointing to termination with the external male spigot of the case uppermost.

Jointing system

All joints in the PMSA chimney range are made by means of a simple push fit jointing method. This is achieved by the engineered spigot and socket system having a pronounced lead-in-edge to ease assembly.

Thermal expansion

All PMSA elements are designed to allow for thermal expansion of the liner within each joint, so there is no requirement for any additional expansion joints.

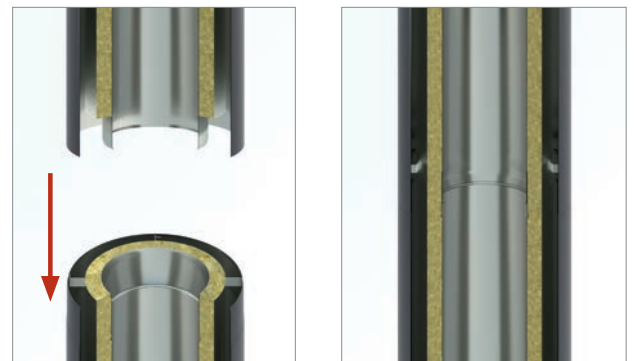

4. Install first chimney inspection pipe with test point depending on the height of the floor a proper pipe length should be used to span the distance between the stove adapter and a ceiling box installed to the bottom level of the floor level above.

Inspection

To conform to Building Regulations, an inspection length must be used directly above the appliance adaptor to allow for cleaning access. To aid cleaning, sufficient distance should be left between changes of direction to permit the safe passage of cleaning brushes within the system. This is particularly important on Wood applications. It is recommended that chimneys serving Wood appliances be swept as frequently as necessary, but at least twice a year.

Installation instructions

Passage through a combustible floor

The chimney from first floor level up can be supported by using a ceiling box fixed between the ceiling joists.

The ceiling box includes retractable pipe which can span the distance of max. 800 mm. When installing the first pipe section be sure the distance between the top end of the pipe and ceiling box is less than 800 mm.

Before continuing to assemble chimney sections, ensure sections being pushed together firmly.

The ceiling box can be installed between ceiling joist with a clearance between 470-560 mm, which can be adjusted with brackets attached on both sides of the ceiling box base plate.

Make sure the ceiling box is installed centred between joists and that min. required distance to combustibles is ensured.

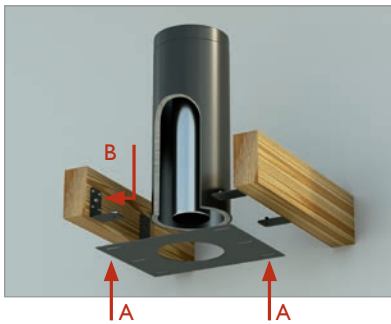
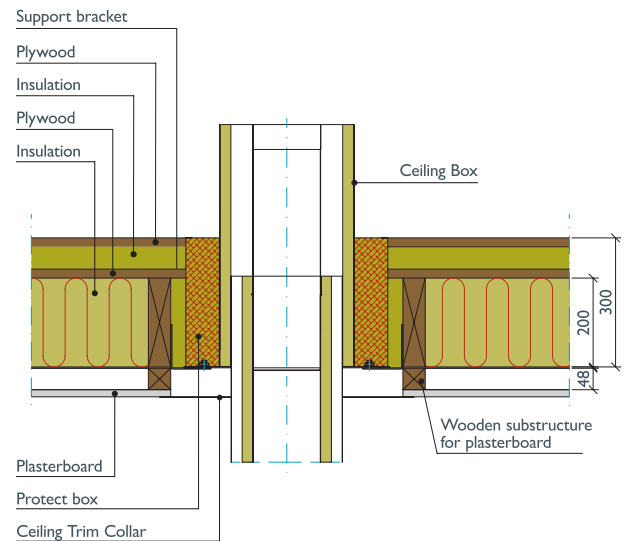

5. Position the ceiling box to the middle between the ceiling beams, flat with the lower side of the beams.

A. Adjust the side brackets to the beams and tighten the M10 bolts firmly.

B. Use 4 Ø 6 mm bolts on each bracket to fix the ceiling box to the beams.

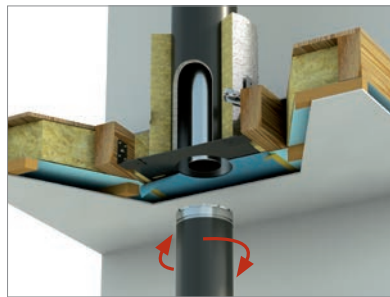

6. Insert lowering pipe into the ceiling box and lock it in place with a fast turn of the pipe. A twist-lock mechanism on the pipe ensures the pipe to remain in place.

Protect Box is lowered into place around the ceiling box and fastened onto the joists.

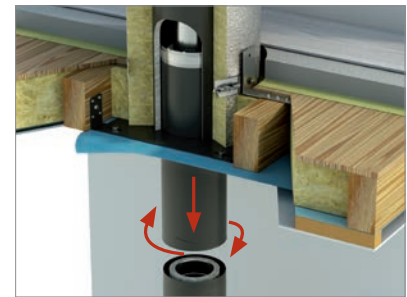

7. After installation of the stove, stove adapter and chimney pipe (see pictures 1-3), release/unlock the lowering pipe by fast turn. Lower the pipe and push it down to fit both pipes together firmly.

Passage through a concrete floor

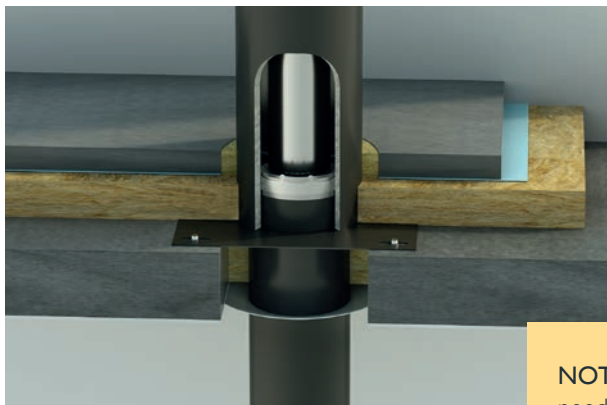

8. Ceiling box can also be used as an anchor plate to support the chimney from concrete floor level up. For installation of a chimney a round hole should be prepared through the floor with the diameter $D_{ext} + \text{min. } 60 \text{ mm}$.

Ceiling box should be positioned to the centre above the hole and anchored to the concrete floor through the drill holes prepared in all sides of ceiling box base plate.

NOTE: Although supporting structure is non-combustible the attention needs to be drawn to insulation layer under the finished floor which needs to be made of mineral fibre boards surrounding the chimney at the required distance to combustibles.

Support components

Passage through ceiling structure using Protect Box

Where chimney penetrates the outside insulation layer of the house (e.g. ceiling) these are normally much thicker than with floor structures between habitable floors, so special attention must be drawn to distance to combustibles – see table on page 6.

Schiedel recommends to use Protect box, a special insulation pipe which prevents combustible structure or insulating materials (e.g. paper flocks) to get in contact with chimney's outer skin. It can span insulation thickness's of up to 600 mm.

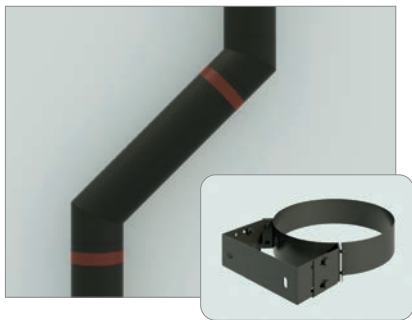

Offset (optional)

In most cases, pipes are installed vertically from bottom to top, but conflict with roof rails or alike can occur, so an offset should be used to avoid obstacle. Check national regulation on required inspection openings when installing offsets to assist cleaning.

A locking band should be mounted on each joint to strengthen installed length. Wall bands should be installed in locations as shown in the picture to support stability of the chimney.



Wall bands

are non load bearing and provide lateral support only. They are used in intermediate chimney section where non supported chimney length exceed max. allowed length. Refer to the load bearing tables on page 10 for full details.

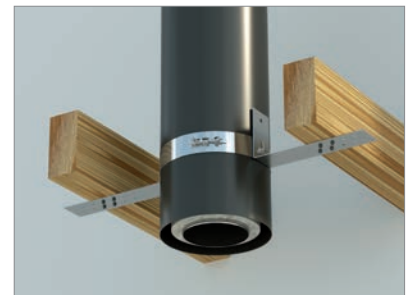

Passage through the roof

Roof structure represent the upper most position for fixing the chimney before transition to the free standing part. We recommend to use a roof support bracket which is supplied as a kit, complete with two side plates for fixing to the roof trusses and a band to give lateral support to the chimney as it passes through the roof. Special attention should be drawn to distance to combustible between the outer case of the chimney and the wooden beams.

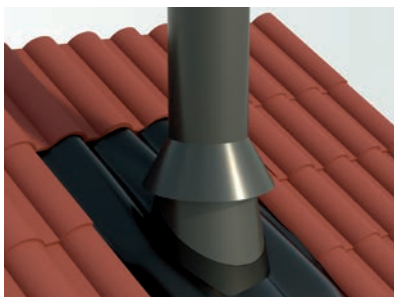

Section above the roof

A chimney penetration should be protected accordingly. We recommend to use our lead or Wakaflex flashings which are available in respective roof angle ranges.

For external applications (above the roof) we recommend that the joints have a bead of silicone sealant applied.

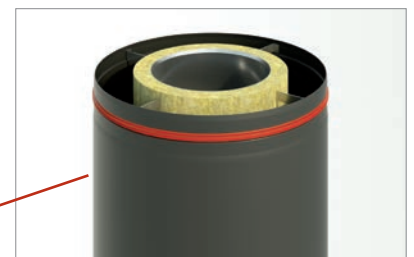

Bead of silicone sealant to be applied on external pipes.

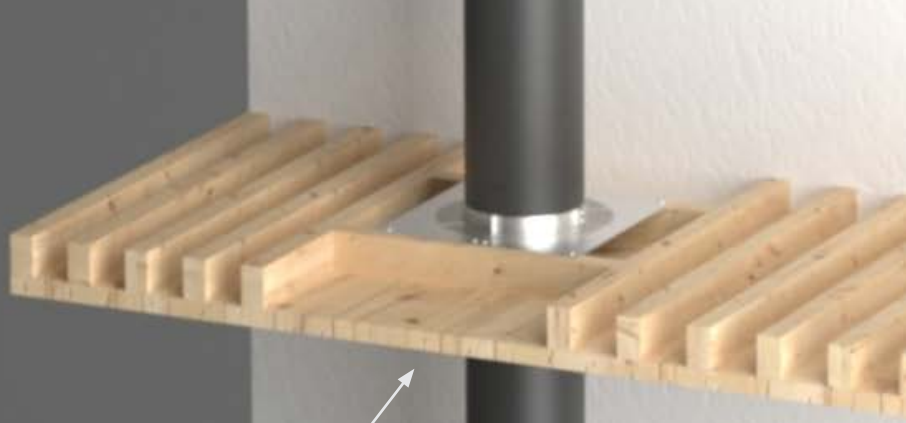

Support detail using ventilated firestops and ventilated support plates.

A ventilated firestop is used on the living room ceiling with a ventilated support plate at first floor level.

A ventilated firestop is used in the bedroom ceiling and then a Protect Box can be used at roof level together with EPDM mats to maintain an air tight envelope within the building



Support components



Structural locking band

A structural locking band (supplied separately) should be used in section above the roof where structural support is required. A maximum of 2,0 m unsupported height can be achieved by fitting the structural locking band on the joint immediately below and on every joint above the last support.



Guy wire bracket

Where the freestanding height should exceed 2,0 m above the last support or above the roof, a guy wire bracket must be used in conjunction with guy wires or rigid stays. Please contact Schiedel technical service for advise on details of installation.

Terminal

The terminal used is designed to ensure sufficient air supply to the Sirius stove, which has been approved as a room sealed appliance.



After installation

CE chimney plate

After installation a chimney plate must be applied. This is the responsibility of the installer.

Maintenance and cleaning

Chimneys should be regularly inspected and cleaned according to the national chimney sweep regulation. Only stainless steel or plastic brushes are allowed to be used for cleaning to avoid corrosion on the flue liner.

Carbon monoxide detector

It is recommended that a Carbon monoxide detector is installed in room or dwelling where a Wood appliance is installed. This should comply with EN 50291.

Please follow manufacturer's instructions with regards to siting and fixing or on the ceiling at least 300 mm from any wall or if it is located on a wall, as high up as possible (above any doors and windows), but not within 150 mm of the ceiling between 1 m and 3 m horizontally from the appliance

N.B Provision of a carbon monoxide detector should not be regarded as a substitute for correct installation and regular servicing.

Product overview



Sirius 1	
SAP Code	157041
Int Ø (mm)	150
Height (mm)	1218
Width (mm)	498



Sirius 3G	
SAP Code	158239
Int Ø (mm)	150
Height (mm)	1218
Width (mm)	498

Glass hearth	
SAP Code	POA
Int Ø (mm)	
Ext Ø1 (mm)	
Ext Ø2 (mm)	

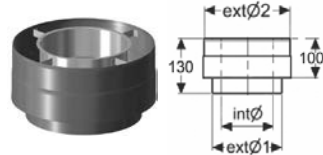

Concentric stove connector (Sirius)	
SAP Code	157842
Int Ø (mm)	150
Ext Ø1 (mm)	200
Ext Ø2 (mm)	250

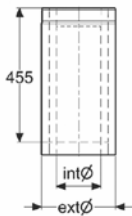

Inspection pipe	
SAP Code	172735
Int Ø (mm)	150
Ext Ø1 (mm)	250
L (mm)	455

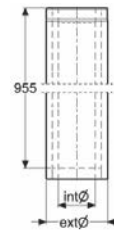

PMSA 25 Pipe element 1000 mm	
SAP Code	118456
Int Ø (mm)	150
Ext Ø1 (mm)	250
Ext Ø2 (mm)	955

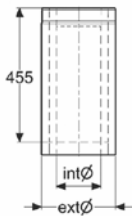

PMSA 25 Pipe element 500 mm	
SAP Code	142700
Int Ø (mm)	150
Ext Ø1 (mm)	250
L (mm)	455

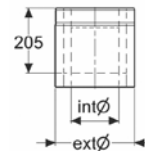

PMSA 25 Pipe element 250 mm	
SAP Code	142704
Int Ø (mm)	150
Ext Ø1 (mm)	250
L (mm)	205

Product overview

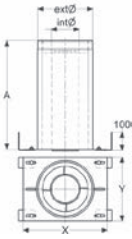

Ceiling box	
SAP Code	151942
X x Y (mm)	460x350
Int Ø (mm)	150
Ext Ø1 (mm)	300
A (mm)	550



Protect box	
SAP Code	121343
Int Ø (mm)	150
Ø D1 (mm)	305
Ø D2 (mm)	460
s (mm)	75

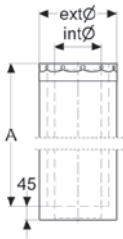

Lowering pipe for ceiling box 1000 mm	
SAP Code	151938
Int Ø (mm)	150
Ext Ø1 (mm)	250
A (mm)	950

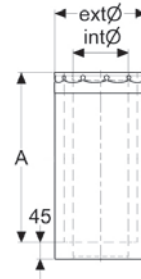

Lowering pipe for ceiling box 500 mm	
SAP Code	152177
Int Ø (mm)	150
Ext Ø1 (mm)	250
A (mm)	455

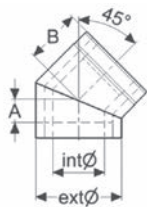

PMSA 25 elbow 45°	
SAP Code	148480
Int Ø (mm)	150
Ext Ø1 (mm)	250
A (mm)	67
B (mm)	157

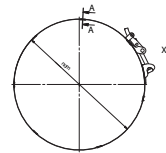

Structural locking band	
SAP Code	110286
Int Ø (mm)	250
Ext Ø1 (mm)	250

Product overview

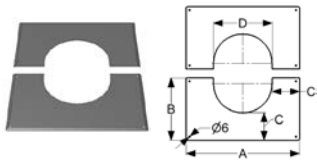

Roof plate 0°- 5° PMSA 25	
SAP Code	111891
Nom. diameter	150
Ext Ø mm	250
Ø D mm	259
Ø A mm	500
Ø B mm	275
Ø C mm	120.5

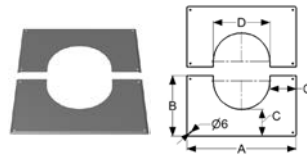

Roof plate 5°- 20° PMSA 25	
SAP Code	111892
Nom. diameter	150
Ext Ø mm	250
Ø D mm	259
Ø A mm	500
Ø B mm	275
Ø C mm	120.5

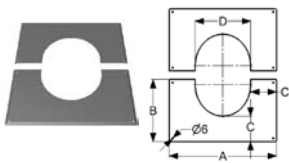

Roof plate 20°- 35° PMSA 25	
SAP Code	111994
Nom. diameter	150
Ext Ø mm	250
Ø D mm	259
Ø A mm	500
Ø B mm	290
Ø C mm	120.5

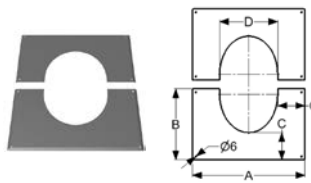

Roof plate 35°- 45° PMSA 25	
SAP Code	112287
Nom. diameter	150
Ext Ø mm	250
Ø D mm	259
Ø A mm	500
Ø B mm	300
Ø C mm	120.5

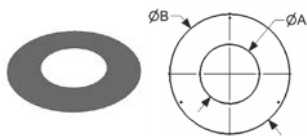

Ceiling trim collar PMSA 25	
24SAP Code	111344
Nom. diameter	150
Ø A mm	258
Ø B mm	457

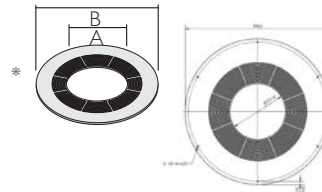

Round ventilated firestop	
SAP Code	173118
Nom. diameter	150
Ø A mm	251.6
Ø B mm	661

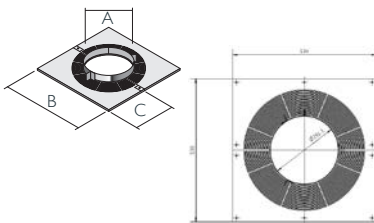

Ventilated support plate	
SAP Code	173120
Nom. diameter	150
Ø A mm	530
Ø B mm	265
Ø C mm	251.6

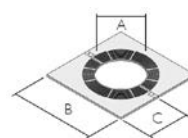

Square ventilated firestop	
SAP Code	173128
Nom. diameter	150
Ø A mm	251.6
Ø B mm	661

Product overview

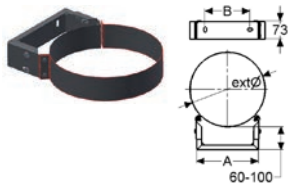

Wall band (adjustable) PMSA 25	
SAP Code	110460
Nom. diameter	150
Ext Ø mm	250
Ø A mm	
Ø B mm	

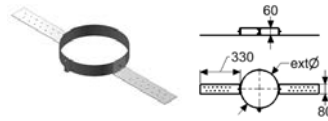

Roof bracket PMSA 25	
SAP Code	100965
Nom. diameter	150
Ext Ø mm	250

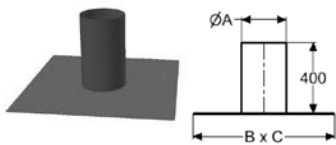

Flat flashing PMSA 25	
SAP Code	117399
Nom. diameter	150
Ext chim.Ø mm	250
Ø A mm	300
H mm	400
B x C mm	800x800

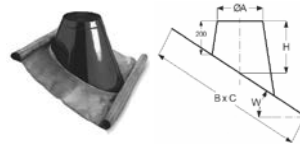

Lead flashing 3-15° PMSA 25	
SAP Code	113940
Nom. diameter	150
Ext chim.Ø mm	250
Ø A mm	300
H mm	233
B x C mm	940x1000

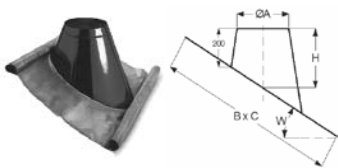

Lead flashing 16-25° PMSA 25	
SAP Code	114030
Nom. diameter	150
Ext chim.Ø mm	250
Ø A mm	300
H mm	267
B x C mm	970x1000

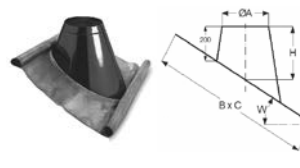

Lead flashing 26-35° PMSA 25	
SAP Code	114031
Nom. diameter	150
Ext chim.Ø mm	250
Ø A mm	300
H mm	307
B x C mm	1020x1000

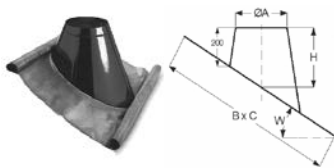

Lead Flashing 36-45° PMSA 25	
SAP Code	114032
Nom. diameter	150
Ext chim.Ø mm	250
Ø A mm	300
H mm	355
B x C mm	1120x1000



Storm Collar PMSA 25	
SAP Code	110460
Nom. diameter	150
Ø A mm	250
Ø B mm	390



Guy wire bracket PMSA 25	
SAP Code	110668
Nom. diameter	150
Ext Ø mm	250

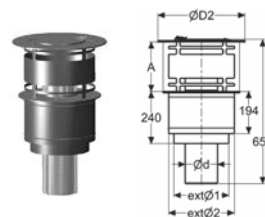

Anti splash terminal PMSA 25	
SAP Code	116577
Int Ø (mm)	150
Ext Ø1 (mm)	250
Ext Ø2 (mm)	300
A (mm)	230
ØD2 (mm)	400

Heating with wood



Renewable resource

Wood is a renewable resource that burns only as much carbon dioxide (CO₂) as it releases from natural decomposition in the forest or as much as the tree captured from the atmosphere during its growth.

High energy value

Firewood has a high energy value. For example, take oak: whilst it has a residual wood moisture content of approx. 15–20%, its calorific value adds up to 4.2 kWh per kilogram.

9% (2020)



13-15% (2035)

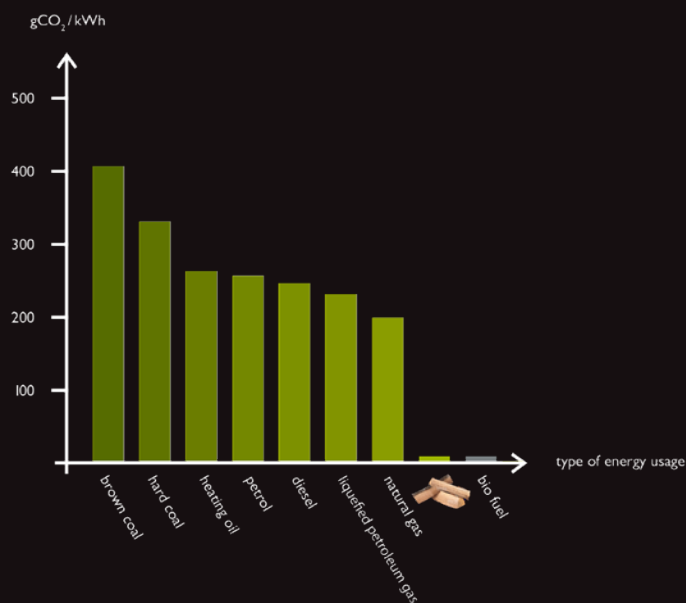

Low emission factor

The impact of air pollution on our health and environment is so significant that it is considered to be the second biggest environmental concern after climate change.

Firewood has a low emission factor in comparison with other energy sources, with a very low primary energy coefficient of 0.2.

European forest is growing

30% of annual forest growth remains in the forest. The area of European forests is increasing by the size of a football field every minute, increasing the potential for carbon capture in the coming decades.

30% of the annual forest increment remains in the forest.



The spark in all of us

The spark in all of us is an internal north star and constant driver of all our ideas and actions. An irrepressible force of nature that constantly pushes us forward and helps us to leave old things behind.

It is the source of our inspiration to make things better, smarter, more sustainable and stay ahead of the game. The spark of our inspiration also jumps over to the people we deal with: our partners, our customers.

THE SPARK

STANDARD-SETTER

We spark tomorrow's industry standards & trends.

PASSIONATE

New ideas for future buildings are constantly sparked by our ingrained passion for smarter, more liveable, sustainable solutions.

CARING

We value and nurture the spark that our people carry and how they transfer it over to our customers.

PARTNERSHIP-ORIENTED

We pro-actively seek our customers feedback to let their needs spark inspiration for new technical solutions and services.

It is in our DNA to answer important questions: How does a modern chimney or fireplace need to look like, to make people happy? What exactly is it, that "sparks" a home with warmth, inspiration and a feeling of cosiness and independence? To answer these questions, we address relevant future trend topics: families, sustainability, product & design and industry.

THE SPARK is our motto under which we want to shed light on future opportunities and how to actively use them.

Spark up your life

The spark is what drives us at Schiedel, and so, looking ahead, we are proactively facing one question: what will the future hold for us?

Only by understanding the key challenges and their effects on our future lives, Schiedel will be able to continue its standard-setting ambitions.

Discover more about the future trends "family", "sustainability", "product & design" and "industry".

FAMILIES



Spending more time at home is becoming an increasingly desirable goal for many people. Thanks to online shopping and home office,

there are even more reasons to create a beautiful home. At home, families strive for maximum comfort – which leads to high expectations when it comes to aesthetics, functionality and, last but not least, convenience. Furthermore, the seamless integration of products into smart homes and on-demand services is of great importance. We are already trying to meet those requirements and contribute to space saving, cozy homes for today's and future homeowners.

SUSTAINABILITY



At no time it has ever been more important for us at Schiedel to offer customers longterm solutions based

on sustainability. Both, you as a customer as well as we as a company want to proactively change the world together.

At Schiedel, we care deeply about the environment; we focus on environmentally friendly and energy-efficient, low-energy solutions, like new filters, hybrid vents and thermo block stones. With the Sirius System, we already provide an energy efficient, and low emission solution suitable for all homes.

PRODUCT & DESIGN



On top of products being valuable and useable, we also need to build products and experiences that are enjoyable – focusing on

how the things we have created make people feel. At Schiedel we learn from and grow with our customers. We design and constantly adjust solutions that are based on customer needs, creating product features that exceed existing norms: clear, simple and effective design that radiates peace, improves well-being and saves space. A Sirius fire creates higher living comfort, quality of life and bring safety and independence to our customer's homes.

INDUSTRY



Climate change and extreme weather phenomena affect industry and economics on many different levels. The number of consci-

ous consumers is growing. We are called upon to take these changes into account when it comes to developing new products as well as innovative services. On our mission to produce sustainably, we will continue to use and search for renewable resources and look for new ways to reduce waste. Internally, we constantly push towards the future through constantly improving our production setup, BIM Offering and 3D CAD.



Schiedel Chimney Systems
Crowther Estate, Washington
Tyne & Wear NE38 0AQ
Tel. +44 (0)191 416 1150

sales.uk@schiedel.com
schiedel.com/uk



Follow us on Social Media @SchiedelUK



A **standard**
INDUSTRIES COMPANY