



EARN SCHIEDEL
INSTALLER REWARDS!

SCHIEDEL

Prima Smooth

Single Wall Stainless Steel Connecting Flue
Pipe and Chimney Liner for Wood and
Multi-fuel Appliances



DON'T FORGET TO REGISTER YOUR INSTALLATIONS
AND START EARNING SCHIEDEL INSTALLER REWARDS
See inside for more details

www.schiedel.com/uk

SAP 940002243 - Updated 26 July 2023

Product Description

Prima Smooth is the new high quality 316L grade stainless steel single wall flue system available with two wall thickness options of 0.6mm and 1mm. There are two possible applications:

1. Connecting Flue Pipe

Prima Smooth has been tested and approved for use as connecting flue pipe between an appliance and a system chimney.

2. Chimney Liner

Prima Smooth has been tested and approved for use as an alternative to a flexible stainless steel liner for re-lining an existing chimney.

Prima Smooth is a lightweight precision engineered product, designed for use on atmospheric wood burning and multi-fuel appliances with continuous operating temperatures of up to 600°C. The joints in the pipe are designed to give a smooth visual appearance and Prima Smooth is available in two surface finishes:

- Matt 316L grade stainless steel.
- Matt black painted 316L grade stainless steel using a special high temperature resistant paint.

Joint Detail

PRODUCT FEATURES

- 316L Grade Stainless Steel
- Corrosion tested
- Lightweight
- Precision engineered jointing system
- Available in matt black or steel finish
- Can be painted
- Range Ø125, 150, 180, 200

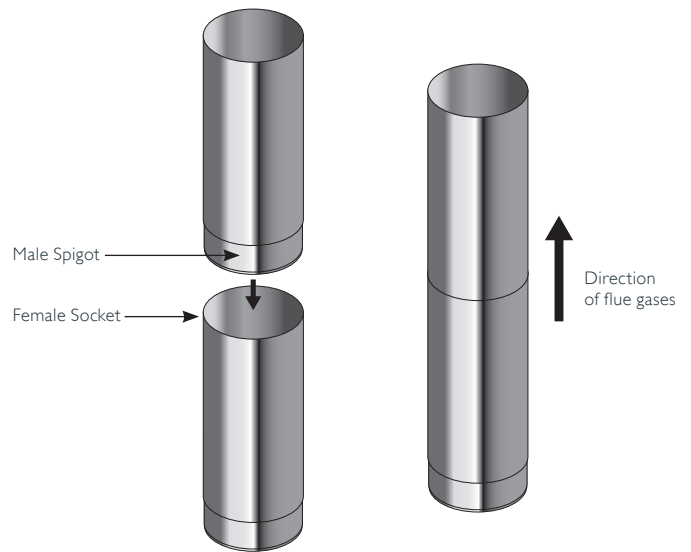

Approvals

High Temperature Applications	High Temperature Applications
Connecting Flue Pipe EN1856-2 TÜV 0036 CPR 9195 029 T600 N1 W V2 L50060 GXX NM T600 N1 W V2 L50100 GXX NM (XX = 3 x Ø Int. of Pipe)	Chimney Liner EN1856-2 TÜV 0036 CPR 9195 033 T600 N1 D V2 L50060 G T600 N1 D V2 L50100 G

TÜV CE



The Prima Smooth range is manufactured under the strict requirements of BS EN ISO 9001 Quality management scheme. Prima Smooth has corrosion certification from TÜV. Prima Smooth is listed by HETAS as a product suitable for solid fuel.

Starting Components

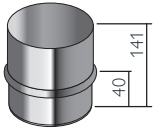

Appliance Connector				0.6mm PS013	1mm PS113
Int Ømm Prima Smooth		125	125	150	150
Appliance Spigot mm		123	128	148	153
SAP Code Painted	0.6mm	125359	125363	126253	126257
SAP Code Unpainted	0.6mm	125361	125365	126255	126259
	1mm	125362	125366	126256	126260

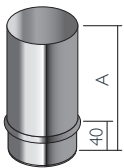

Swaged Starter Pipes					
Int Ømm Prima Smooth			125	150	180
Appliance Spigot mm			123	148	178
SAP Code Unpainted A 1000	1mm		133956	133959	133965
SAP Code Unpainted A 500	1mm		133957	133960	133966
SAP Code Unpainted A 250	1mm		133958	133961	133967

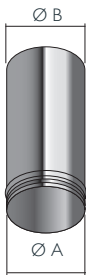

Swaged Starter Pipe with Locator Bead				
Int Ømm Prima Smooth			125	150
A			122	147
B			131	156
SAP Code Unpainted			176014	176015



Adaptor to TecnoFlex Plus					
Int Ømm Prima Smooth		125/125	125/155	150/155	180/180
Int Ømm Prima Smooth		125	125	150	180
Int Ømm TecnoFlex Plus		125	155	155	200
SAP Code Painted	0.6mm	110180	COA	110413	-
SAP Code Unpainted	0.6mm	110176	119949	110411	120028

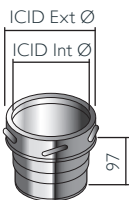

Adaptor to ICID Plus				0.6mm PS027	
Int Ømm Prima Smooth		125	150	180	200
Int Ømm ICID		125	150	180	200
Ext Ømm ICID		180	200	238	256
SAP Code Painted	0.6mm	109991	110268	126980	127587
SAP Code Unpainted	0.6mm	109992	110270	126981	127588

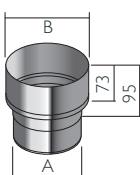

Increaser				0.6mm PS091	1mm PS191
Increaser type		100/125	120150	150/180	180/200
Int A Ømm from		100	125	150	180
to Int B Ømm		125	150	180	200
SAP Code Painted	0.6mm	119928	110195	126292	-
	1mm	124895	110735	-	-
SAP Code Unpainted	0.6mm	110068	110205	126293	-
	1mm	110066	110211	126294	126984

COA: code on application

Starting Components

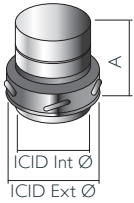

Adaptor from ICID					
Int Ømm Prima Smooth		125	150	180	200
Int Ømm ICID		125	150	180	200
Ext Ømm ICID		180	200	238	256
A		135	135	137	137
SAP Code Unpainted	0.6mm	145516	145517	145518	145519

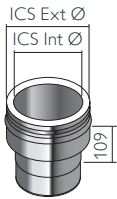

Adaptor to ICS25						0.6mm PS068
Int Ømm Prima Smooth		125	150	180	200	
Int Ømm ICID		125	150	180	200	
Ext Ømm ICID		180	200	230	250	
SAP Code Unpainted	0.6mm	125388	126291	134132	144449	

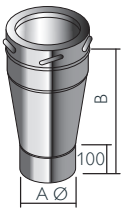

SW-DW Adjustable Starter Section to ICID.						DN8A159	DN8A161
* Increasing SW-DW Adjustable Starter Section							
Int Ømm ICID		125	125*	150	180	200	
Ext Ømm ICID		180	200	200	235	256	
A		123	123	148	178	198	
B		352	434	352	352	352	
SAP Code Painted	0.6mm	125339	131148	126117	126849	-	
SAP Code Unpainted	0.6mm	125340	126096	126118	126850	127435	
This component MUST only be fitted to stove pipe and NOT directly to appliance.							

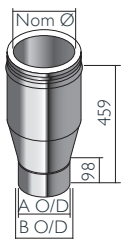

SW-DW Adjustable Starter Section to ICS25.						
* Increasing SW-DW Adjustable Starter Section						
Int Ømm ICS		130	130*	150	180	200
Ext Ømm ICS		180	200	200	230	250
A O/D		122.7	122.7	147.6	176.5	197.5
B O/D		130	130	154.5	183.5	204.5
SAP Code Unpainted	0.6mm	133653	143702	133654	133655	133656
This component MUST only be fitted to stove pipe and NOT directly to appliance.						

Pipes

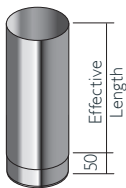

Standard Pipe Effective Length 950mm					0.6mm PS001	1mm PS101
Int Ømm		125	150	180	200	
SAP Code Painted	0.6mm	122583	114554	119860	119858	
	1mm	122584	119954	119957	119955	
SAP Code Unpainted	0.6mm	113272	114550	119861	119859	
	1mm	115948	116338	119958	119956	

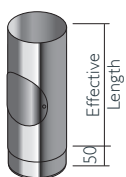

Inspection Pipe Effective Length 950mm					0.6mm PS011	1mm PS111
Int Ømm		125	150	180		
SAP Code Painted	0.6mm	114177	114707	-	-	
	1mm	115979	116477	-	-	
SAP Code Unpainted	0.6mm	114179	114709	-	-	
	1mm	113482	114708	-	119962	

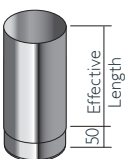

Standard Pipe Effective Length 450mm					0.6mm PS002	1mm PS102
Int Ømm		125	150	180	200	
SAP Code Painted	0.6mm	122585	111973	119868	119866	
	1mm	125375	120601	119965	119963	
SAP Code Unpainted	0.6mm	111487	111972	119869	119867	
	1mm	112994	113393	119966	119964	

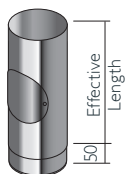

Inspection Pipe Effective Length 450mm					0.6mm PS012	1mm PS112
Int Ømm		125	150	180		
SAP Code Painted	0.6mm	112081	112155	-	-	
	1mm	114182	114252	-	-	
SAP Code Unpainted	0.6mm	112083	112150	-	-	
	1mm	111608	112115	-	119970	

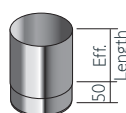

Standard Pipe Effective Length 200mm					0.6mm PS003	1mm PS103
Int Ømm		125	150	180	200	
SAP Code Painted	0.6mm	122586	110716	119880	119878	
	1mm	125374	120602	-	-	
SAP Code Unpainted	0.6mm	110485	110723	119881	119879	
	1mm	111302	111543	119978	119976	

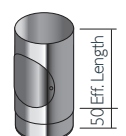

Inspection Pipe Effective Length 250mm					0.6mm PS004	1mm PS104
Int Ømm		125	150	180	200	
SAP Code Painted	0.6mm	122587	111169	-	-	
SAP Code Unpainted	1mm	110850	110850	119974	119972	

Pipes



Cover Band					0.6mm PS029
Int Ømm		125	150	180	200
SAP Code Painted	0.6mm	125386	126289	-	-
SAP Code Unpainted	0.6mm	125387	126290	126979	127586

This component is used to provide a more aesthetic finish to the joint if pipe lengths are cut down on site.



Locking Band					0.6mm PS030
Int Ømm		125	150	180	200
SAP Codes Unpainted	0.6mm	125390	126296	126985	127589

This component is used to provide extra support where there is an offset in the system and may also be used to clamp the joints when Prima Smooth is being lowered down a chimney as a chimney liner.



Adjustable Pipe Lengths (200mm)					0.6mm PS085	1mm PS185
Int Ømm		125	150	180	200	
Max Adjustment mm		70	70	70	70	
SAP Code Painted	0.6mm	125384	126288	119888	119886	
	1mm	125385	126287	119884	119883	
SAP Code Unpainted	0.6mm	125380	126283	119889	-	
	1mm	125381	126284	119885	119882	

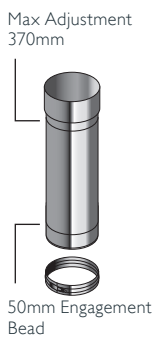

Adjustable Pipe Lengths (500mm)					0.6mm PS385	1mm PS485
Int Ømm		125	150	180	200	
Min Adjustment mm		80	70	70	80	
Max Adjustment mm		370	370	370	370	
SAP Code Painted	0.6mm	125382	126285	126976	127583	
	1mm	125379	126282	126975	127582	
SAP Code Unpainted	0.6mm	125383	126286	126977	127584	
	1mm	125358	126252	126948	127556	

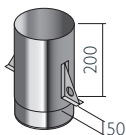

Lowering Pipe					0.6mm PS333	1mm PS433
Int Ømm		125	150	180	200	
SAP Code Unpainted	1mm	125391	126297	-	-	

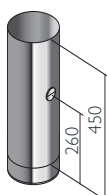

Test Point					
Int Ømm		125	150	180	200
SAP Code Painted	0.6mm	146361	146365	-	-
SAP Code Unpainted	1mm	146362	146366	-	-

Tees

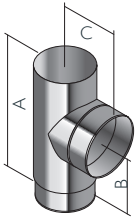

90° Tee					0.6mm PS014 1mm PS114
Int Ømm		125	150	180	200
A		283	325	450	450
B		118	139	200	200
C		94	109	124	134
SAP Code Painted	0.6mm	111126	111688	-	-
	1mm	112205	113028	-	-
SAP Code Unpainted	0.6mm	111108	111689	119898	-
	1mm	111156	111600	119991	119989

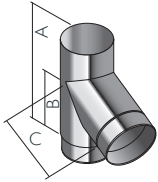

135° Tee					0.6mm PS016 1mm PS116
Int Ømm		125	150	180	200
A		283	325	450	450
B		180	215	295	305
C		178	215	258	281
SAP Code Painted	0.6mm	111334	111909	-	-
	1mm	-	-	-	-
SAP Code Unpainted	0.6mm	-	111917	126974	-
	1mm	119987	119986	126972	127579

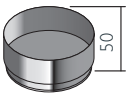

Tee Cap					0.6mm PS017
Int Ømm		125	150	180	200
SAP Code Painted	0.6mm	122595	122596	126992	-
SAP Code Unpainted	0.6mm	109826	109919	126993	127597

Bends

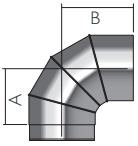

Adjustable 0-90° Bend					0.6mm PS005	1mm PS105
Int Ømm		125	150	180	200	
A mm		127	142	158	176	
B mm		174	184	199	216	
SAP Code Unpainted	0.6mm	110821	111295	-	-	
	1mm	111870	112484	120003	120002	

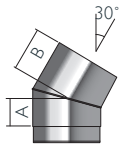

30° Bend					0.6mm PS070	1mm PS170
Int Ømm		125	150	180	200	
A		50	50	50	50	
B		98	98	98	98	
SAP Code Painted	0.6mm	110194	110488	-	-	
	1mm	120022	111145	-	-	
SAP Code Unpainted	0.6mm	110213	110494	119920	119918	
	1mm	110258	110493	120017	120015	

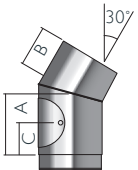

30° Inspection Bend					0.6mm PS039	1mm PS139
Int Ømm			125		150	
A mm			181		181	
B mm			98		98	
C mm			100		100	
Inspection Hole Ø mm			100		130	
SAP Code Painted	1mm		110938		111320	
SAP Code Unpainted	0.6mm		111004		111356	

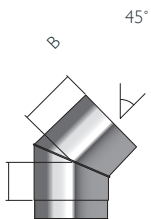

45° Bend					0.6mm PS015	1mm PS115
Int Ømm		125	150	180	200	
A mm		73	73	73	73	
B mm		122	122	122	122	
SAP Code Painted	0.6mm	121422	110717	-	119909	
	1mm	122589	120013	-	-	
SAP Code Unpainted	0.6mm	110468	110720	119912	119910	
	1mm	110515	110707	120008	120006	

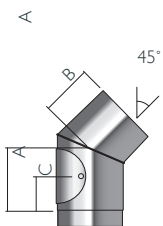

45° Inspection Bend					0.6mm PS044	1mm PS144
Int Ømm		125	150	180	200	
A mm		155	155	155	155	
B mm		122	122	122	122	
C mm		94	94	94	94	
Inspection Hole Ø mm		100	130	130	130	
SAP Code Painted	0.6mm	122594	111335	-	-	
	1mm	121423	120004	-	-	
SAP Code Unpainted	0.6mm	-	111332	-	-	
	1mm	110948	111324	120012	120010	

Bends

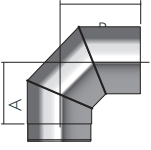

90° Bend				0.6mm PS051	1mm PS151
Int Ømm		125	150	180	200
A mm		131	131	134	134
B mm		190	190	184	184
SAP Code Painted	0.6mm	122590	111106	-	119899
	1mm	122591	120001	-	-
SAP Code Unpainted	0.6mm	110881	111117	119902	119900
	1mm	110852	111151	119996	119994

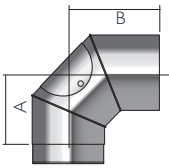

90° Inspection Bend				0.6mm PS028	1mm PS128
Int Ømm		125		150	
A mm		131		131	
B mm		190		190	
Inspection Hole Ø mm			100		130
SAP Code Painted	0.6mm		122592		111353
	1mm		122593		119992
SAP Code Unpainted	0.6mm		110883		111354
	1mm		111019		111323

Integral 45° Offsets

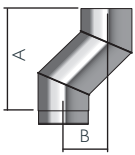

100 mm Offset			
Int Ømm		125	150
A mm		300	300
B mm		100	100
SAP Code Unpainted	1mm	146683	145192

Offsets (made by assembling 2 bends)

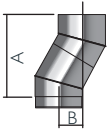

30° Offset				
Int Ømm	125	150	180	200
A mm	276	276	276	276
B mm	74	74	74	74

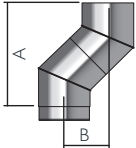

45° Offset				
Int Ømm	125	150	180	200
A mm	333	333	333	333
B mm	138	138	138	138

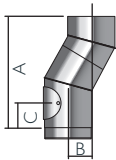

30° Offset (using Inspection Bend)				
Int Ømm	125	150	180	200
A mm	407	407	407	407
B mm	74	74	74	74
C mm	100	100	100	100

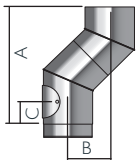

45° Offset (using Inspection Bend)				
Int Ømm	125	150	180	200
A mm	415	415	415	415
B mm	138	138	138	138
C mm	94	94	94	94

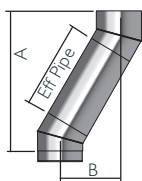

30° Offset with standard Pipe lengths					
Int Ømm		125	150	180	200
Effective Pipe 950	A mm	1099	1099	1099	1099
	B mm	549	549	549	549
Effective Pipe 450	A mm	666	666	666	666
	B mm	299	299	299	299
Effective Pipe 200	A mm	449	449	449	449
	B mm	174	174	174	174

Offsets (made by assembling 2 bends)

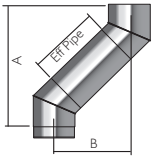

45° Offset with standard Pipe lengths					
Int Ømm		125	150	180	200
Effective Pipe 950	A mm	1005	1005	1005	1005
	B mm	810	810	810	810
Effective Pipe 450	A mm	651	651	651	651
	B mm	456	456	456	456
Effective Pipe 200	A mm	474	474	474	474
	B mm	279	279	279	279

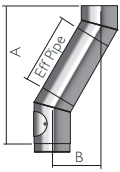

30° Offset using Inspection Bend					
Int Ømm		125	150	180	200
Effective Pipe 950	A mm	1230	1230	1230	1230
	B mm	549	549	549	549
Effective Pipe 450	A mm	797	797	797	797
	B mm	299	299	299	299
Effective Pipe 200	A mm	580	580	580	580
	B mm	174	174	174	174

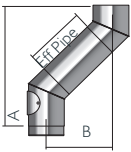

45° Offset with standard Pipe lengths (using Inspection Bend)					
Int Ømm		125	150	180	200
Effective Pipe 950	A mm	1087	1087	1087	1087
	B mm	810	810	810	810
Effective Pipe 450	A mm	733	733	733	733
	B mm	456	456	456	456
Effective Pipe 200	A mm	556	556	556	556
	B mm	279	279	279	279

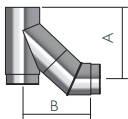

Offsets for 135° Tee & 45° Bend					
Int Ømm		125	150	180	200
A mm		348	386	432	458
B mm		315	348	424	430

Support Components

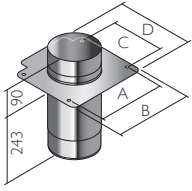

Support Plate				0.6mm PS0F1	1mm PS1F1
Int Ømm		125	150	180	200
A mm		185	210	240	260
B mm		221	246	276	296
C mm		105	130	160	180
D mm		190	215	245	265
SAP Code Unpainted	0.6mm	125396	126302	-	-
	1mm	-	126301	126990	-
Pipe length is adjustable to allow for thermal expansion.					

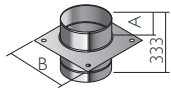

Expansion Joint				0.6mm PS031	1mm PS131
Int Ømm		125	150	180	200
A mm		60	60	60	60
B mm		400	400	400	400
SAP Code Unpainted	0.6mm	125155	125848	-	-
	1mm	125156	125849	-	127162
Pipe length is adjustable to allow for thermal expansion.					

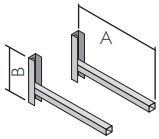

Cantilever Support			Type 325 95420001	Type 475 95420002
Type		325		475
Ømm Range		125-200		125-200
A mm		325		475
B mm		242		242
SAP Codes		101742		101743

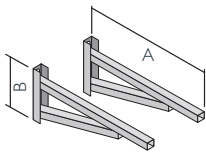

Cantilever Support			Type 570 95420003
Type			570
Ømm Range			125-200
A mm			570
B mm			330
SAP Codes			101744

Terminals



Raincap Locking Band				0.6mm S030	
Int Ømm		125	150	180	200
SAP Code Unpainted	0.6mm	144487	144489	144490	144491

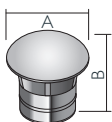

Raincap				0.6mm S036	
Int Ømm		125	150	180	200
A mm		266	266	362	362
B mm		139	158	180	183
SAP Code Unpainted	0.6mm	125161	110761	111525	111556
This component is designed to be used exclusively in conjunction with the Expansion Joint at the top of an existing masonry stack.					

Typical Installations

CONNECTION TO INTERNAL SYSTEM CHIMNEY

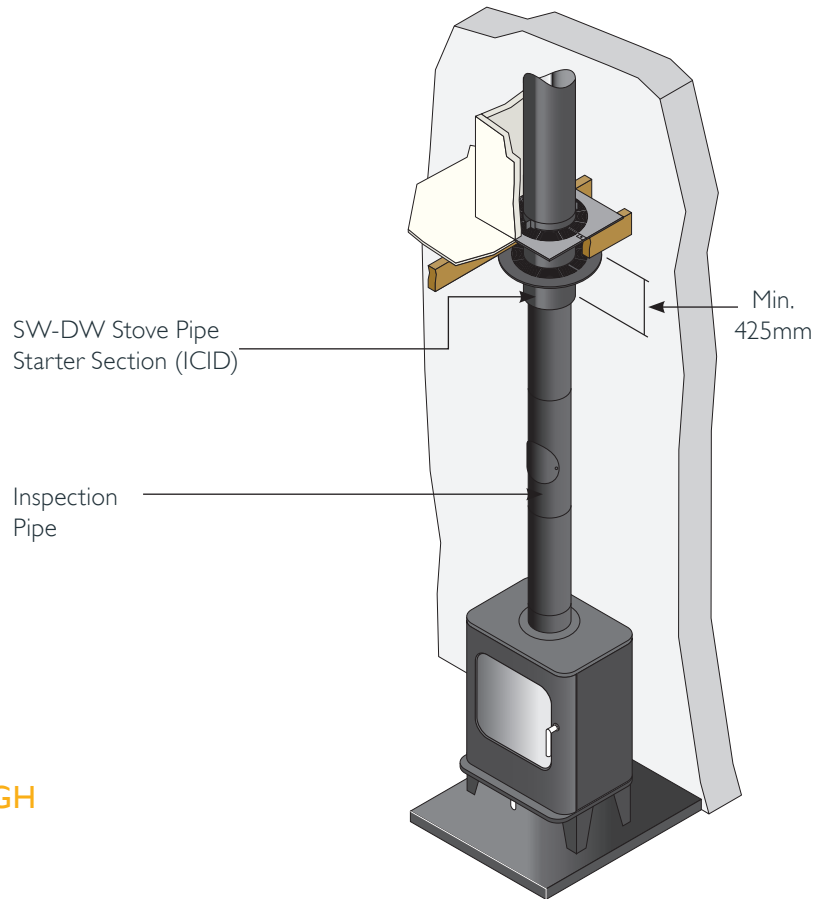

CONNECTION TO FLEX THROUGH FIREPLACE RECESS

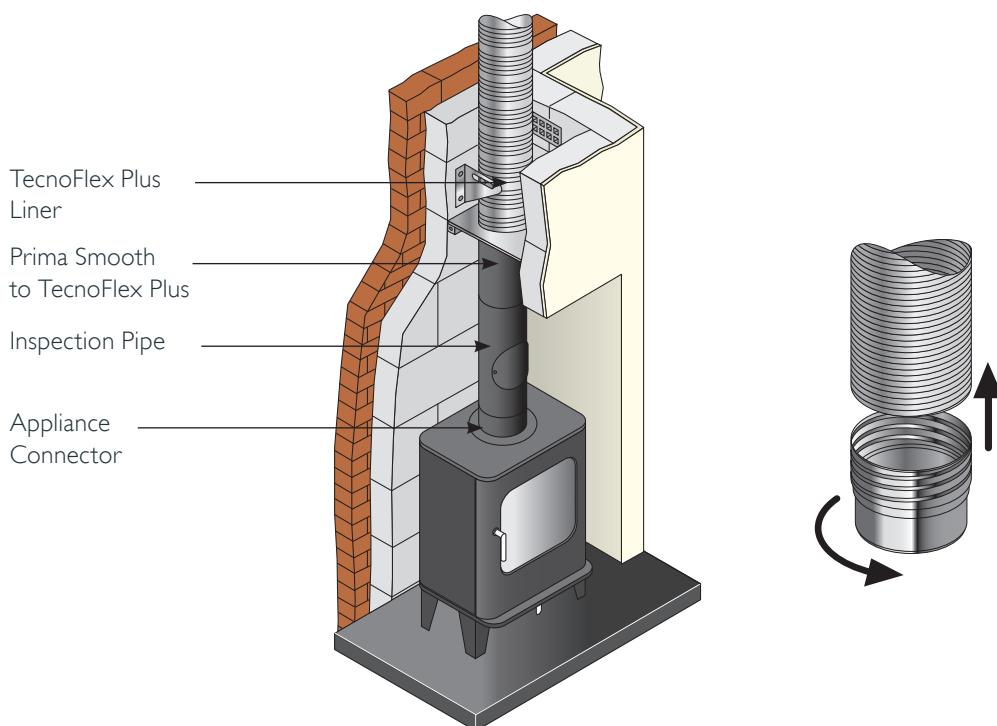

Typical Installations

CHIMNEY LINER ON INSET FIRE

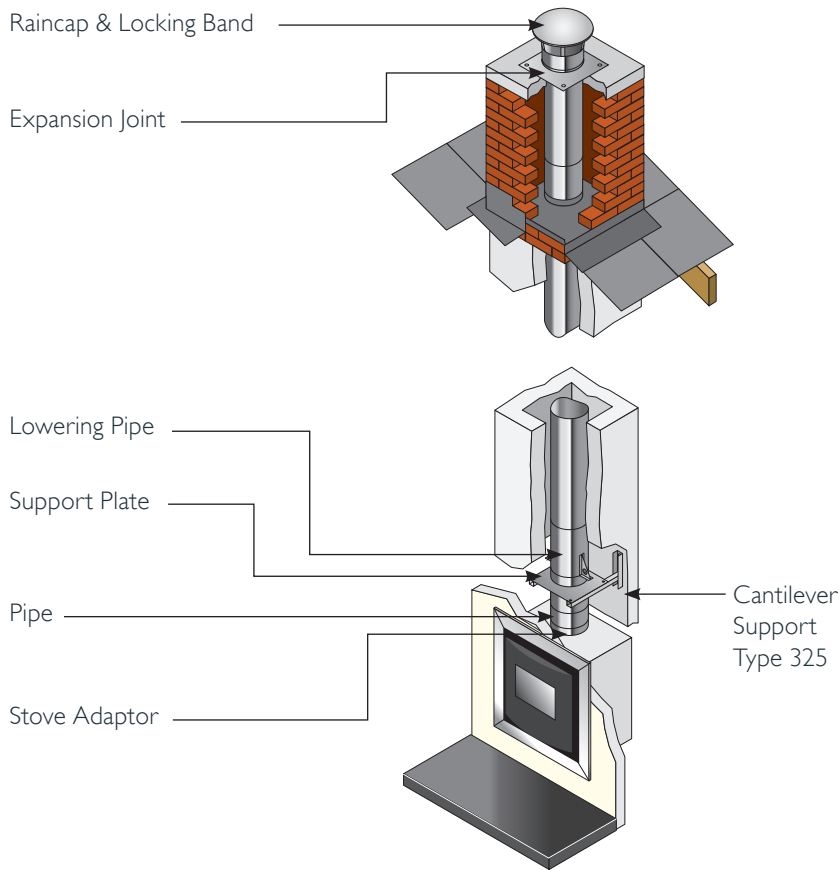

CONNECTION TO MODULAR PUMICE OR CERAMIC SYSTEM CHIMNEY

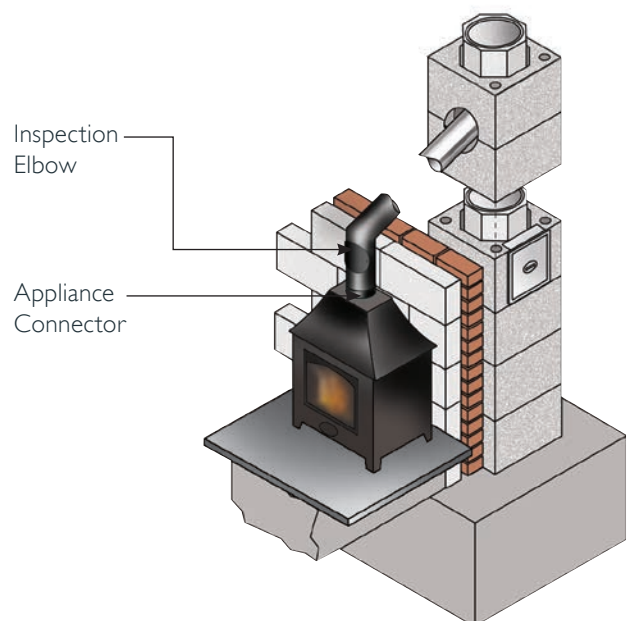

Useful Guides

THE SCHIEDEL INSTALLATION APP

This handy mobile guide can be used on mobile devices and touchscreen tablets.

It offers a number of very useful guides on all aspects of installing an appliance using Schiedel Chimney Systems, including:

- Quick and straightforward reference for installers.
- Video breakdowns of each stage of the installation process, from connection to the appliance through to termination.
- Highlighting the safety critical areas where the chimney penetrates the floors, ceilings, roof and walls.
- Incorporates frequently asked questions information at each stage of the installation process, in line with building regulations.
- An easy-to-use system for downloading full product information and installation instructions.
- Register your Guarantee in the App.

Download the iPhone and iPad version in the App Store and Android version in the Google Play Store.

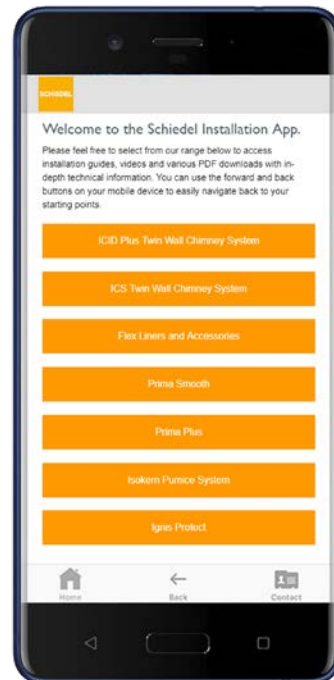

DOWNLOADS SPECIALIST CENTRE

We have a comprehensive range of CAD cells, typical installations using Isokern Pumice components and other diagrams, which are ideal resources for architects and builders when designing a chimney system for a new build or renovation.

Visit our website and head over to the **SPECIALIST CENTRE** which can be found under the **SCHIEDEL WORLD** menu, or contact us and we will send a USB stick with all the relevant information and downloads on.

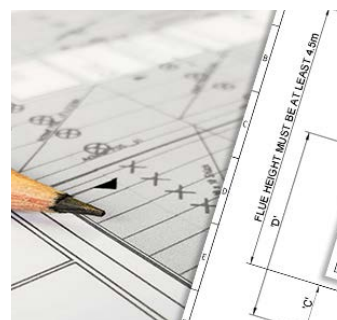

Schiedel Installer Rewards

Exciting news from Schiedel Chimney Systems for Stove and Chimney Installers! Whenever you register an installation with our easy to use, online guarantee registration portal, you will now accrue points based on the number of installations and installation type.

Once you have reached a minimum of 25 points, you can begin to redeem them for £25 Love2Shop vouchers.

So head on over to the portal and start to register your installations to start earning points!



Complementary Products and Services from Schiedel Chimney Systems



ICID PLUS

The NEW highly Insulated Twin Wall System Chimney for traditional stoves, pellet stoves, biomass appliances, mini/micro CHP and condensing boilers capable of withstanding positive pressure.

- Easy twist lock connection
- Effective insulation
- 100-200mm Internal diameter range



PRIMA PLUS

Single Wall Stainless Steel Flue System

- Prima Plus available 0.6mm or 1mm options for domestic multi-fuel stoves
- Prima Plus for large residential & commercial condensing gas & oil appliances & chimney relining
- 80-300mm Diameter range

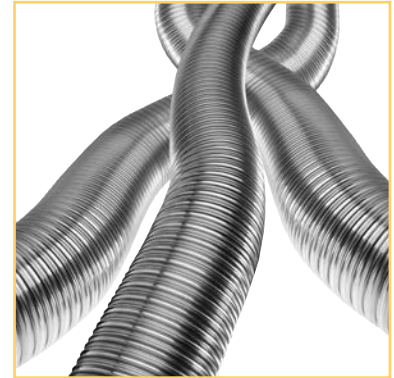

TECNOFLEX PLUS

For relining existing chimneys to take gas, oil, wood, multi-fuel appliances and open fires.

- Twin skin TecnoFlex Plus available in 316L or 904L options for oil, wood, multi-fuel & open fires
- 80-300mm Diameter range



ICS

Twin Wall Insulated System Chimney for gas, oil and multi-fuel applications.

- Simple push-fit jointing system
- High efficiency Superwool insulation blanket
- Capillary break prevents moisture being drawn through the joint
- 80-300mm Diameter range

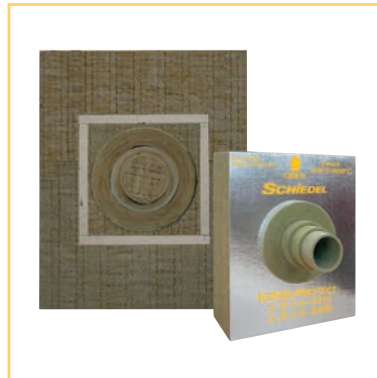

IGNIS-PROTECT

Designed specifically for Air Tight, Energy Efficient and Timber Framed Buildings

- Suitable for SW and DW connecting flue pipes passing through interior or exterior walls made of combustible materials
- Available in both 90° and 45° version



DM & LINERS

Pumice System Chimneys, Firechests and Liners.

- Pumice is a natural insulator, able to maintain the temperature of flue gases
- Lightweight – allowing one person to lift and build the chimney units
- Pumice expands and contracts less with temperature change than other chimney systems.

SCHIEDEL

Schiedel Chimney Systems Ltd.
Crowther Road, Crowther Ind. Est.
Washington, Tyne & Wear
NE38 0AQ
Tel: +44 191 4161150

sales.uk@schiedel.com
www.schiedel.com/uk

SCHIEDEL INSTALLER REWARDS

Exciting news from Schiedel Chimney Systems! Whenever you register an installation with our easy to use, online guarantee registration portal, you will now accrue points based on the number of installations and installation type to redeem for Love2Shop vouchers!



Follow us on Social Media @SchiedelUK



A standard
INDUSTRIES COMPANY